

X069/301

NATIONAL
QUALIFICATIONS
2000

WEDNESDAY, 31 MAY
9.00 AM – 11.30 AM

PHYSICS
HIGHER

Read Carefully

- 1 All questions should be attempted.

Section A (questions 1 to 20)

- 2 Check that the answer sheet is for Physics Higher (Section A).
- 3 Answer the questions numbered 1 to 20 on the answer sheet provided.
- 4 Fill in the details required on the answer sheet.
- 5 Rough working, if required, should be done only on this question paper, or on the first two pages of the answer book provided—**not** on the answer sheet.
- 6 For each of the questions 1 to 20 there is only **one** correct answer and each is worth 1 mark.
- 7 Instructions as to how to record your answers to questions 1–20 are given on page three.

Section B (questions 21 to 29)

- 8 Answer questions numbered 21 to 29 in the answer book provided.
- 9 Fill in the details on the front of the answer book.
- 10 Enter the question number clearly in the margin of the answer book beside each of your answers to questions 21 to 29.
- 11 Care should be taken to give an appropriate number of significant figures in the final answers to calculations.

DATA SHEET
COMMON PHYSICAL QUANTITIES

| Quantity | Symbol | Value | Quantity | Symbol | Value |
|--|--------|-------------------------------------|------------------|--------|------------------------------------|
| Speed of light in vacuum | c | $3.00 \times 10^8 \text{ m s}^{-1}$ | Mass of electron | m_e | $9.11 \times 10^{-31} \text{ kg}$ |
| Magnitude of the charge on an electron | e | $1.60 \times 10^{-19} \text{ C}$ | Mass of neutron | m_n | $1.675 \times 10^{-27} \text{ kg}$ |
| Gravitational acceleration | g | 9.8 m s^{-2} | Mass of proton | m_p | $1.673 \times 10^{-27} \text{ kg}$ |
| Planck's constant | h | $6.63 \times 10^{-34} \text{ J s}$ | | | |

REFRACTIVE INDICES

The refractive indices refer to sodium light of wavelength 589 nm and to substances at a temperature of 273 K.

| Substance | Refractive index | Substance | Refractive index |
|-------------|------------------|-----------|------------------|
| Diamond | 2.42 | Water | 1.33 |
| Crown glass | 1.50 | Air | 1.00 |

SPECTRAL LINES

| Element | Wavelength/nm | Colour | Element | Wavelength/nm | Colour |
|----------|---------------|-------------|----------------|----------------------|---------------|
| Hydrogen | 656 | Red | Cadmium | 644 | Red |
| | 486 | Blue-green | | 509 | Green |
| | 434 | Blue-violet | | 480 | Blue |
| | 410 | Violet | <i>Lasers</i> | | |
| | 397 | Ultraviolet | <i>Element</i> | <i>Wavelength/nm</i> | <i>Colour</i> |
| | 389 | Ultraviolet | Carbon dioxide | 9550 } 10590 } | Infrared |
| Sodium | 589 | Yellow | Helium-neon | 633 | Red |

PROPERTIES OF SELECTED MATERIALS

| Substance | Density/ kg m^{-3} | Melting Point/ K | Boiling Point/ K |
|-----------|--------------------------------|---------------------|---------------------|
| Aluminium | 2.70×10^3 | 933 | 2623 |
| Copper | 8.96×10^3 | 1357 | 2853 |
| Ice | 9.20×10^2 | 273 | |
| Sea Water | 1.02×10^3 | 264 | 377 |
| Water | 1.00×10^3 | 273 | 373 |
| Air | 1.29 | | |
| Hydrogen | 9.0×10^{-2} | 14 | 20 |

The gas densities refer to a temperature of 273 K and a pressure of $1.01 \times 10^5 \text{ Pa}$.

SECTION A

For questions 1 to 20 in this section of the paper, an answer is recorded on the answer sheet by indicating the choice A, B, C, D or E by a stroke made in ink in the appropriate box of the answer sheet—see the example below.

EXAMPLE

The energy unit measured by the electricity meter in your home is the

- A ampere
- B kilowatt-hour
- C watt
- D coulomb
- E volt.

The correct answer to the question is B—kilowatt-hour. Record your answer by drawing a heavy vertical line joining the two dots in the appropriate box on your answer sheet in the column of boxes headed B. The entry on your answer sheet would now look like this:

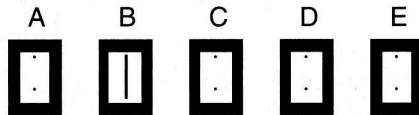

If after you have recorded your answer you decide that you have made an error and wish to make a change, you should cancel the original answer and put a vertical stroke in the box you now consider to be correct. Thus, if you want to change an answer D to an answer B, your answer sheet would look like this:

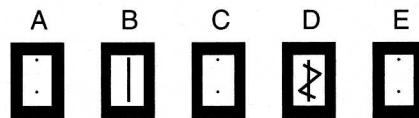

If you want to change back to an answer which has already been scored out, you should enter a tick (✓) to the RIGHT of the box of your choice, thus:

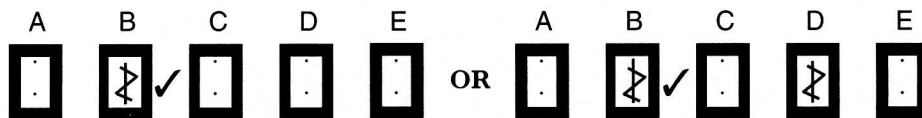

SECTION A

Answer questions 1–20 on the answer sheet.

1. Which of the following is a scalar quantity?

- A Velocity
- B Acceleration
- C Mass
- D Force
- E Momentum

2. A woman walks 12 km due North. She then turns round immediately and walks 4 km due South. The total journey takes 4 hours.

Which row in the following table gives the correct values for her average velocity and average speed?

| | <i>Average velocity</i> | <i>Average speed</i> |
|---|----------------------------|----------------------|
| A | 4 km h ⁻¹ due N | 4 km h ⁻¹ |
| B | 4 km h ⁻¹ due N | 2 km h ⁻¹ |
| C | 3 km h ⁻¹ due N | 4 km h ⁻¹ |
| D | 2 km h ⁻¹ due N | 4 km h ⁻¹ |
| E | 2 km h ⁻¹ due N | 3 km h ⁻¹ |

3. The following velocity-time graph describes the motion of a ball, dropped from rest and bouncing several times.

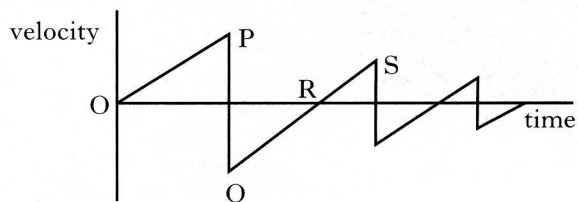

Which of the following statements is/are true?

- I The ball hits the ground at P.
 - II The ball is moving upwards between Q and R.
 - III The ball is moving upwards between R and S.
- A I only
 - B II only
 - C III only
 - D I and II only
 - E I and III only

4. The momentum of a rock of mass 4 kg is 12 kg m s⁻¹.

The kinetic energy of the rock is

- A 6 J
- B 18 J
- C 36 J
- D 144 J
- E 288 J.

5. Density is measured in

- A N m⁻²
- B N m⁻³
- C kg m³
- D kg m⁻²
- E kg m⁻³.

6. The pressure of a fixed mass of gas is 100 kPa at a temperature of -52°C . The volume of the gas remains constant.

At what temperature would the pressure of the gas be 200 kPa?

- A -26°C
- B $+52^{\circ}\text{C}$
- C $+147^{\circ}\text{C}$
- D $+169^{\circ}\text{C}$
- E $+442^{\circ}\text{C}$

7. The end of a bicycle pump is sealed with a stopper so that the air in the chamber is trapped.

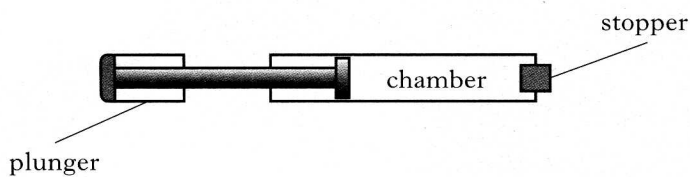

The plunger is now pushed in slowly causing the air in the chamber to be compressed. As a result of this the pressure of the trapped air increases.

Assuming that the temperature remains constant, which of the following explain/s why the pressure increases?

- I The air molecules increase their average speed.
- II The air molecules are colliding more often with the walls of the chamber.
- III Each air molecule is striking the walls of the chamber with greater force.

- A II only
- B III only
- C I and II only
- D I and III only
- E I, II and III

8. One volt is

- A one coulomb per joule
- B one joule coulomb
- C one joule per coulomb
- D one joule per second
- E one coulomb per second.

9. In the following circuit the reading on the voltmeter is zero.

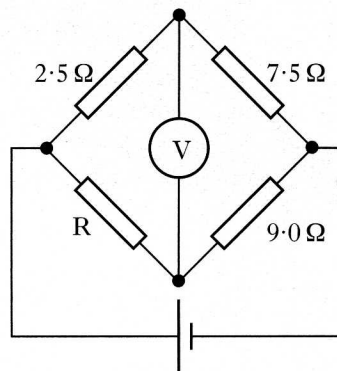

The resistance of resistor R is

- A $0.33\ \Omega$
- B $0.48\ \Omega$
- C $2.1\ \Omega$
- D $3.0\ \Omega$
- E $27\ \Omega$.

[Turn over

10. The circuits below have identical a.c. supplies which are set at a frequency of 200 Hz. A current is registered on each of the ammeters A_1 and A_2 .

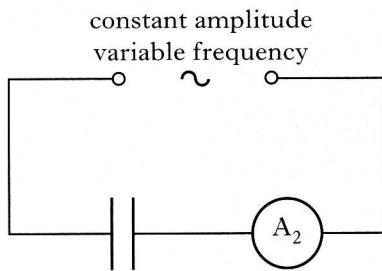
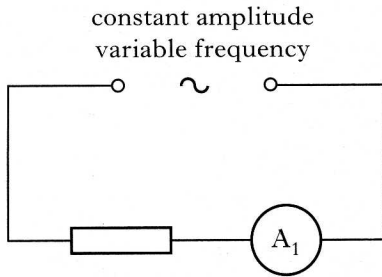

The frequency of each a.c. supply is now increased to 500 Hz.

What happens to the readings on ammeters A_1 and A_2 ?

| | A_1 | A_2 |
|---|-----------|-----------|
| A | increases | decreases |
| B | decreases | increases |
| C | no change | no change |
| D | no change | decreases |
| E | no change | increases |

11. A student makes the following statements about ideal op-amps.

I An op-amp used in the inverting mode inverts the input signal.

II The gain equation for the inverting mode is

$$\frac{V_o}{V_i} = -\frac{R_1}{R_f}$$

where the symbols have their usual meanings.

III An op-amp used in the differential mode amplifies the sum of its two input voltages.

Which of the above statements is/are correct?

- A I only
 B II only
 C III only
 D I and II only
 E I, II and III

12. An op-amp circuit is connected as shown below.

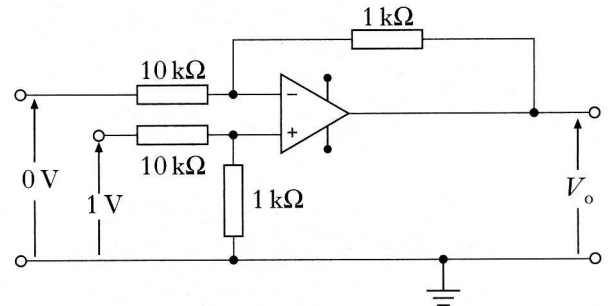

What is the value of the output voltage V_o ?

- A 10 V
 B 0.1 V
 C 0 V
 D -0.1 V
 E -10 V

13. The circuit below is used to generate square waves. The amplitude of the alternating input voltage is 6 V.

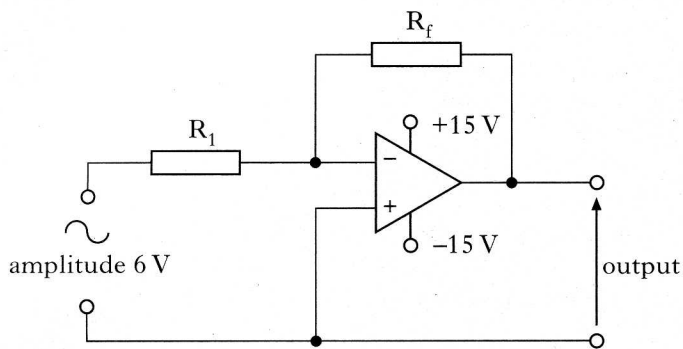

Which values for resistors R_1 and R_f will produce an approximate square wave output?

| | R_1 | R_f |
|---|---------------|---------------|
| A | 1 k Ω | 10 k Ω |
| B | 5 k Ω | 10 k Ω |
| C | 10 k Ω | 10 k Ω |
| D | 10 k Ω | 5 k Ω |
| E | 10 k Ω | 1 k Ω |

14. Waves from coherent sources, S_1 and S_2 , produce an interference pattern. Maxima of intensity are detected at the positions shown below.

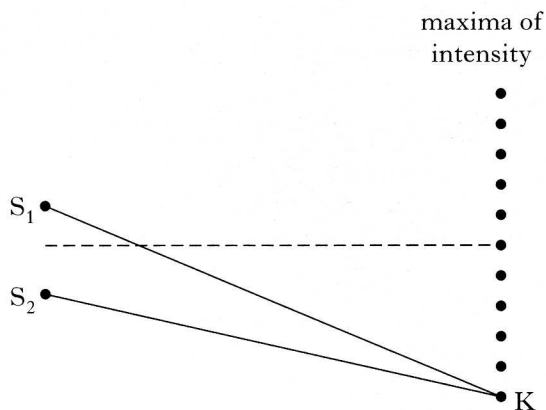

The path difference $S_1K - S_2K$ is 154 mm. The wavelength of the waves is

- A 15.4 mm
 B 25.7 mm
 C 28.0 mm
 D 30.8 mm
 E 34.2 mm.

15. When white light passes through a grating, maxima of intensity are produced on a screen, as shown below. The central maximum is white. Continuous spectra are obtained at positions P and Q.

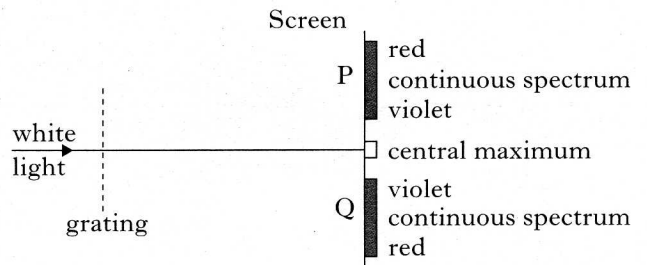

In the continuous spectra, violet is observed closest to the central maximum.

Which of the following statements is/are true?

- I Violet light has the shortest wavelength of all the visible radiations.
 II Violet light has the longest wavelength of all the visible radiations.
 III Violet light travels faster through air than the other visible radiations.
- A I only
 B II only
 C III only
 D I and III only
 E II and III only

16. A ray of light passes from air into a substance that has a refractive index of 2.0. In air, the light has a wavelength λ and frequency f .

Which row in the following table gives the wavelength and frequency of the light in the substance?

| | Wavelength | Frequency |
|---|-------------|-----------|
| A | λ | f |
| B | $\lambda/2$ | $f/2$ |
| C | $\lambda/2$ | f |
| D | 2λ | $2f$ |
| E | 2λ | f |

[Turn over

17. The diagram below shows a ray of red light passing through a semicircular block of glass.

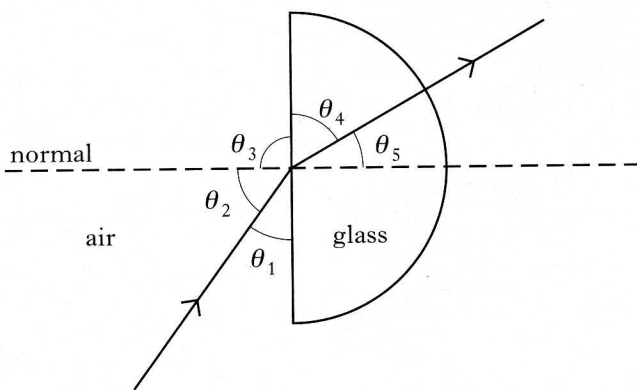

The refractive index of the glass for this light can be calculated from

- A $\frac{\sin \theta_3}{\sin \theta_4}$
 B $\frac{\sin \theta_1}{\sin \theta_4}$
 C $\frac{\sin \theta_2}{\sin \theta_5}$
 D $\frac{\sin \theta_2}{\sin \theta_4}$
 E $\frac{\sin \theta_1}{\sin \theta_5}$

18. The statement below represents a nuclear reaction.

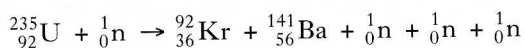

This is an example of

- A nuclear fusion
 B alpha particle emission
 C beta particle emission
 D spontaneous nuclear fission
 E induced nuclear fission.

19. A radioactive source that emits gamma radiation is kept in a large container. A count rate of 160 counts per minute, after correction for background radiation, is recorded outside the container.

The container is to be shielded so that the corrected count rate at the same point outside the container is no more than 10 counts per minute.

Lead and water are available as shielding materials. For this source, the half-value thickness of lead is 11 mm and the half-value thickness of water is 110 mm.

Which of the following shielding arrangements will comply with the above requirement?

- A 40 mm of lead only
 B 33 mm of lead plus 110 mm of water
 C 20 mm of lead plus 220 mm of water
 D 11 mm of lead plus 275 mm of water
 E 10 mm of lead plus 330 mm of water

20. The diagram below represents possible energy levels of an atom.

| | |
|---------|-----------------------------------|
| P _____ | $-5.2 \times 10^{-19} \text{ J}$ |
| Q _____ | $-9.0 \times 10^{-19} \text{ J}$ |
| R _____ | $-16.4 \times 10^{-19} \text{ J}$ |
| S _____ | $-24.6 \times 10^{-19} \text{ J}$ |

Which of the following statements is/are true?

- I There are four emission lines in the spectrum produced as a result of transitions between the energy levels shown.
 II The radiation emitted with the shortest wavelength is produced by an electron falling from level P to level S.
 III The zero energy level in an energy level diagram is known as the ionisation level.
- A I and II only
 B I and III only
 C II and III only
 D III only
 E I, II and III

SECTION B

Write your answers to questions 21 to 29 in the answer book.

Marks

21. At a funfair, a prize is awarded if a coin is tossed into a small dish. The dish is mounted on a shelf above the ground as shown.

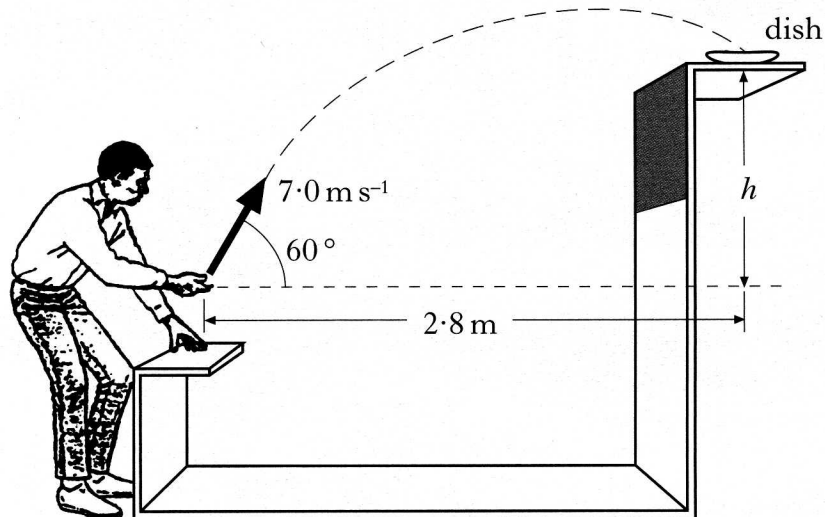

A contestant projects the coin with a speed of 7.0 m s^{-1} at an angle of 60° to the horizontal. When the coin leaves his hand, the **horizontal distance** between the coin and the dish is 2.8 m . The coin lands in the dish.

The effect of air friction on the coin may be neglected.

(a) Calculate:

- (i) the horizontal component of the initial velocity of the coin;
- (ii) the vertical component of the initial velocity of the coin.

2

(b) Show that the time taken for the coin to reach the dish is 0.8 s .

1

(c) What is the height, h , of the shelf above the point where the coin leaves the contestant's hand?

2

(d) How does the value of the kinetic energy of the coin when it enters the dish compare with the kinetic energy of the coin just as it leaves the contestant's hand?

Justify your answer.

2

(7)

[Turn over

22. The apparatus shown below is used to test concrete pipes.

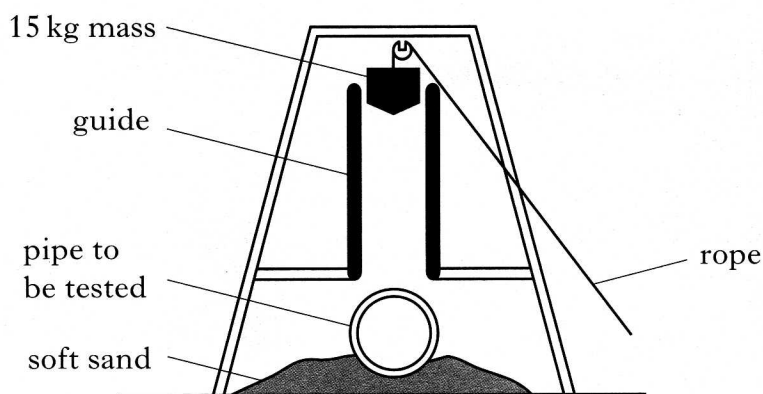

When the rope is released, the 15 kg mass is dropped and falls freely through a distance of 2.0 m on to the pipe.

- (a) In one test, the mass is dropped on to an uncovered pipe.
- (i) Calculate the speed of the mass just before it hits the pipe.
 - (ii) When the 15 kg mass hits the pipe the mass is brought to rest in a time of 0.02 s. Calculate the size and direction of the average unbalanced force on the **pipe**.

5

- (b) The same 15 kg mass is now dropped through the same distance on to an identical pipe which is covered with a thick layer of soft material.

Describe and explain the effect this layer has on the size of the average unbalanced force on the pipe.

2

- (c) Two 15 kg masses, X and Y, shaped as shown, are dropped through the same distance on to identical uncovered concrete pipes.



When the masses hit the pipes, the masses are brought to rest in the same time.

Which mass causes more damage to a pipe?

Explain your answer in terms of pressure.

2

(9)

23. A sonar detector is attached to the bottom of a fresh water loch by a vertical cable as shown.

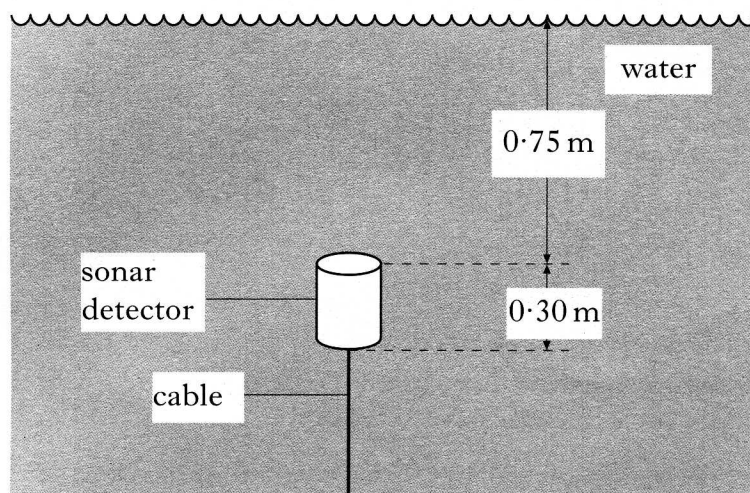

The detector has a mass of 100 kg. Each end of the detector has an area of 0.40 m^2 . Atmospheric pressure is 101 000 Pa.

- (a) The total pressure on the top of the detector is 108 350 Pa.

Show that the total pressure on the bottom of the detector is 111 290 Pa. 2

- (b) Calculate the upthrust on the detector. 3

- (c) The sonar detector is now attached, as before, to the bottom of a **sea water** loch. The top of the detector is again 0.75 m below the surface of the water.

How does the size of the upthrust on the detector now compare with your answer to (b)?

You must justify your answer. 2

(7)

[Turn over

24. (a) In an experiment to measure the capacitance of a capacitor, a student sets up the following circuit.

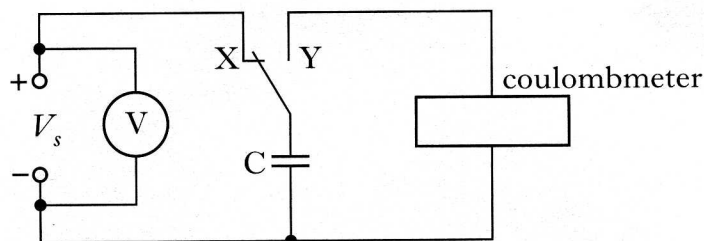

When the switch is in position X, the capacitor charges up to the supply voltage, V_s . When the switch is in position Y, the coulombmeter indicates the charge stored by the capacitor.

The student records the following measurements and uncertainties.

Reading on voltmeter = $(2.56 \pm 0.01) \text{ V}$

Reading on coulombmeter = $(32 \pm 1) \mu\text{C}$

Calculate the value of the capacitance and the percentage uncertainty in this value. You must give the answer in the form

value \pm percentage uncertainty.

3

- (b) The student designs the circuit shown below to switch off a lamp after a certain time.

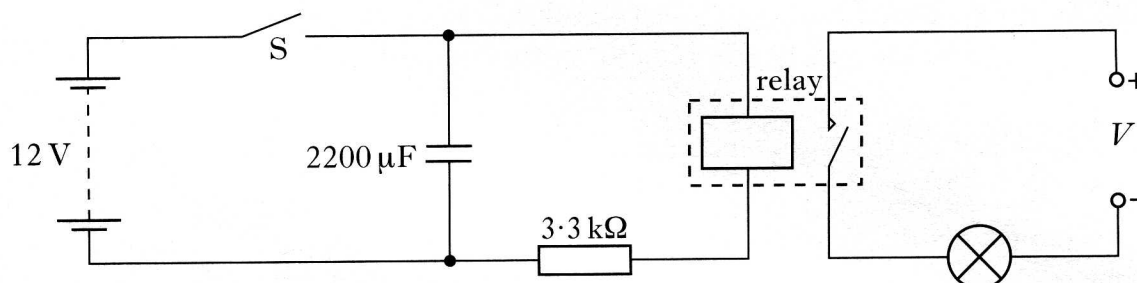

The 12 V battery has negligible internal resistance.

The relay contacts are normally open. When there is a current in the relay coil the contacts close and complete the lamp circuit.

Switch S is initially closed and the lamp is on.

- (i) What is the maximum energy stored in the capacitor?
- (ii) (A) Switch S is now opened. Explain why the lamp stays lit for a few seconds.
- (B) The $2200 \mu\text{F}$ capacitor is replaced with a $1000 \mu\text{F}$ capacitor.

Describe and explain the effect of this change on the operation of the circuit.

6
(9)

