

# 3220/202

---

SCOTTISH  
CERTIFICATE OF  
EDUCATION  
1996

FRIDAY, 17 MAY  
1.30 PM – 4.00 PM

PHYSICS  
HIGHER GRADE  
Paper II

**Read carefully**

- 1 All questions should be attempted.
- 2 Enter the question number clearly in the margin beside each question.
- 3 Any necessary data will be found in the Data Sheet on page two.
- 4 Care should be taken not to give an unreasonable number of significant figures in the final answers to calculations.
- 5 Square-ruled paper (if used) should be placed inside the front cover of the answer book for return to the Examination Board.



**DATA SHEET**  
COMMON PHYSICAL QUANTITIES

Quantity	Symbol	Value	Quantity	Symbol	Value
Speed of light in vacuum	$c$	$3.00 \times 10^8 \text{ m s}^{-1}$	Mass of electron	$m_e$	$9.11 \times 10^{-31} \text{ kg}$
Charge on electron	$e$	$-1.60 \times 10^{-19} \text{ C}$	Mass of proton	$m_p$	$1.673 \times 10^{-27} \text{ kg}$
Gravitational acceleration	$g$	$9.8 \text{ m s}^{-2}$			
Planck's constant	$h$	$6.63 \times 10^{-34} \text{ J s}$			

**REFRACTIVE INDICES**

The refractive indices refer to sodium light of wavelength 589 nm and to substances at a temperature of 273 K.

Substance	Refractive index	Substance	Refractive index
Diamond	2.42	Glycerol	1.47
Glass	1.51	Water	1.33
Ice	1.31	Air	1.00
Perspex	1.49		

**SPECTRAL LINES**

Element	Wavelength/nm	Colour	Element	Wavelength/nm	Colour
Hydrogen	656	Red	Cadmium	644	Red
	486	Blue-green		509	Green
	434	Blue-violet		480	Blue
	410	Violet	<i>Lasers</i>		
	397	Ultraviolet	<i>Element</i>	<i>Wavelength/nm</i>	<i>Colour</i>
	389	Ultraviolet	Carbon dioxide	9550 } 10590 }	Infrared
Sodium	589	Yellow	Helium-neon	633	Red

**PROPERTIES OF SELECTED MATERIALS**

Substance	Density/ $\text{kg m}^{-3}$	Melting Point/ K	Boiling Point/ K	Specific Heat Capacity/ $\text{J kg}^{-1} \text{ K}^{-1}$	Specific Latent Heat of Fusion/ $\text{J kg}^{-1}$	Specific Latent Heat of Vaporisation/ $\text{J kg}^{-1}$
Aluminium	$2.70 \times 10^3$	933	2623	$9.02 \times 10^2$	$3.95 \times 10^5$	....
Copper	$8.96 \times 10^3$	1357	2853	$3.86 \times 10^2$	$2.05 \times 10^5$	....
Glass	$2.60 \times 10^3$	1400	....	$6.70 \times 10^2$	....	....
Ice	$9.20 \times 10^2$	273	....	$2.10 \times 10^3$	$3.34 \times 10^5$	....
Glycerol	$1.26 \times 10^3$	291	563	$2.43 \times 10^3$	$1.81 \times 10^5$	$8.30 \times 10^5$
Methanol	$7.91 \times 10^2$	175	338	$2.52 \times 10^3$	$9.9 \times 10^4$	$1.12 \times 10^6$
Sea Water	$1.02 \times 10^3$	264	377	$3.93 \times 10^3$	....	....
Water	$1.00 \times 10^3$	273	373	$4.19 \times 10^3$	$3.34 \times 10^5$	$2.26 \times 10^6$
Air	1.29	....	....	....	....	....
Hydrogen	$9.0 \times 10^{-2}$	14	20	$1.43 \times 10^4$	....	$4.50 \times 10^5$
Nitrogen	1.25	63	77	$1.04 \times 10^3$	....	$2.00 \times 10^5$
Oxygen	1.43	55	90	$9.18 \times 10^2$	....	$2.40 \times 10^5$

The gas densities refer to a temperature of 273 K and a pressure of  $1.01 \times 10^5 \text{ Pa}$ .

1. The manufacturers of tennis balls require that the balls meet a given standard.

When dropped from a certain height onto a test surface, the balls must rebound to within a limited range of heights.

The ideal ball is one which, when dropped from rest from a height of 3.15 m, rebounds to a height of 1.75 m as shown below.

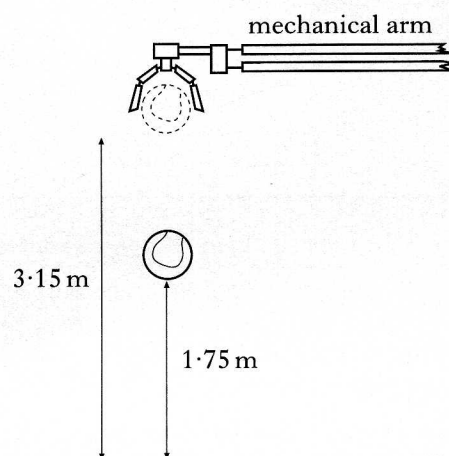

- (a) Assuming air resistance is negligible, calculate
- the speed of an ideal ball just before contact with the ground
  - the speed of this ball just after contact with the ground.
- (b) When a ball is tested six times, the rebound heights are measured to be 1.71 m, 1.78 m, 1.72 m, 1.76 m, 1.73 m, 1.74 m.

3

Calculate

- the mean value of the height of the bounce
- the random error in this value.

3

(6)

[Turn over

2. A child on a sledge slides down a slope which is at an angle of  $20^\circ$  to the horizontal as shown below.

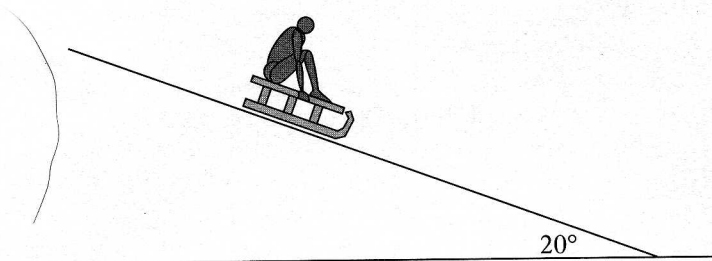

The combined weight of the child and the sledge is 400 N. The frictional force acting on the sledge and child at the start of the slide is 20.0 N.

- (a) (i) Calculate the component of the combined weight of the child and sledge down the slope.
- (ii) Calculate the initial acceleration of the sledge and child. 4
- (b) The child decides to start the slide from further up the slope. Explain whether or not this has any effect on the initial acceleration. 2
- (c) During the slide, the sledge does not continue to accelerate but reaches a constant speed. Explain why this happens. 2

(8)

3. During a test on car safety, two cars as shown below are crashed together on a test track.

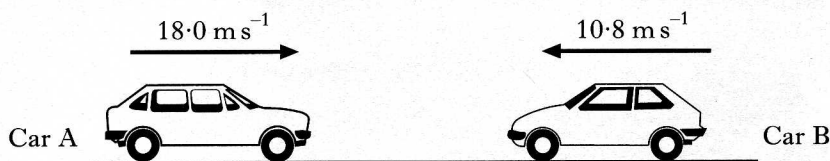

(a) Car A, which has a mass of  $1200 \text{ kg}$  and is moving at  $18.0 \text{ m s}^{-1}$ , approaches car B, which has a mass of  $1000 \text{ kg}$  and is moving at  $10.8 \text{ m s}^{-1}$ , in the opposite direction.

The cars collide head on, lock together and move off in the direction of car A.

- (i) Calculate the speed of the cars immediately after the collision.
- (ii) Show by calculation that this collision is inelastic.

4

(b) During a second safety test, a dummy in a car is used to demonstrate the effects of a collision.

During the collision, the head of the dummy strikes the dashboard at  $20 \text{ m s}^{-1}$  as shown below and comes to rest in  $0.02 \text{ s}$ .

The mass of the head is  $5 \text{ kg}$ .

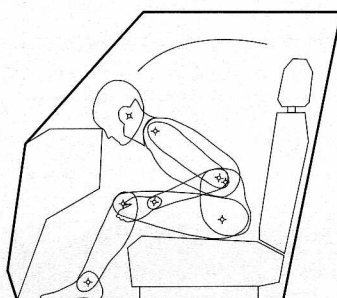

- (i) Calculate the average force exerted by the dashboard on the head of the dummy during the collision.
- (ii) If the contact area between the head and the dashboard is  $5 \times 10^{-4} \text{ m}^2$ , calculate the pressure which this force produces on the head of the dummy.
- (iii) The test on the dummy is repeated with an airbag which inflates during the collision. During the collision, the head of the dummy again travels forward at  $20 \text{ m s}^{-1}$  and is brought to rest by the airbag.

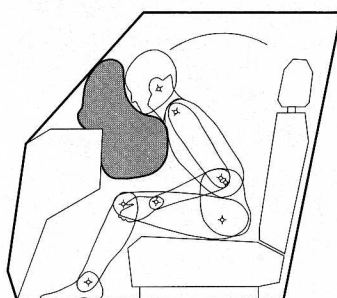

Explain why there is less risk of damage to the head of the dummy when the airbag is used.

5  
(9)

4. The diagram below illustrates an experiment to investigate the relationship between pressure and volume of a gas.

The apparatus consists of a calibrated syringe fitted with a gas-tight piston. Air is trapped in the syringe and the pressure of the trapped air can be monitored using a pressure sensor and a meter.

The pressure of the trapped air can be altered by exerting a force on the piston.

The temperature of the trapped air is assumed to be constant during the experiment.

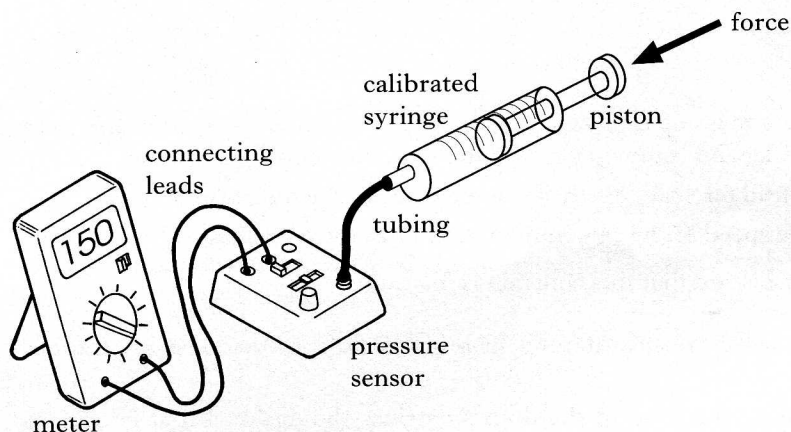

The following measurements of pressure and volume are recorded.

Pressure/kPa	100	150	200	250
Volume/cm <sup>3</sup>	14.7	9.9	7.4	5.9

- (a) Using all the data, establish the relationship between the pressure and volume of the trapped air. 2
- (b) The force on the piston is now altered until the volume of the trapped air is 5.0 cm<sup>3</sup>. Calculate the pressure of the trapped air. 2
- (c) The force is now removed from the piston. Explain the subsequent motion of the piston in terms of the movement of the air molecules. 2
- (d) The tubing between the syringe and the pressure sensor is replaced by one of longer length. What effect would this have on the results of the experiment? 1
- (7)**

5. A Wheatstone bridge is used to monitor the temperature of gas in a pipe.  
 A length of platinum resistance wire forms one part of the Wheatstone bridge circuit. The wire is inserted into the pipe containing the gas as shown below. The 9 V supply has negligible internal resistance.

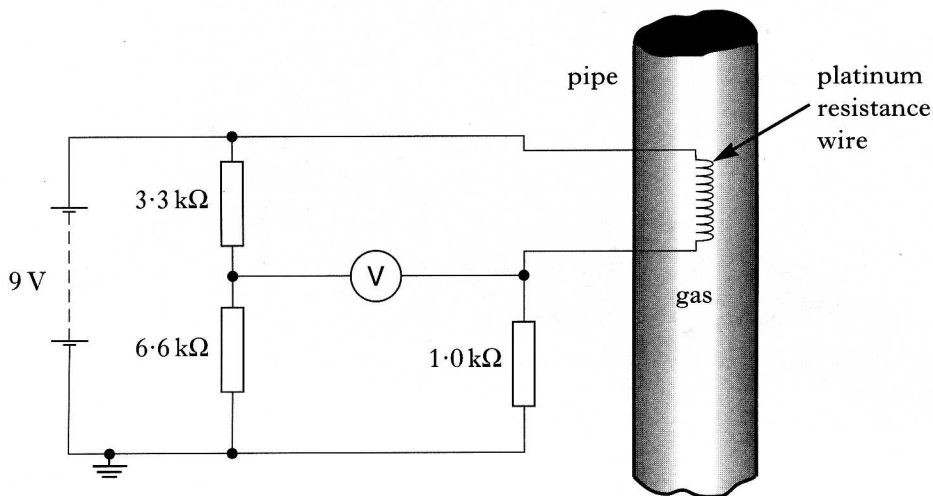

- (a) (i) The bridge is initially balanced. What is the reading on the voltmeter?  
 (ii) Calculate the resistance of the platinum wire.
- (b) The graph below shows how the resistance of the platinum wire varies with temperature.

3

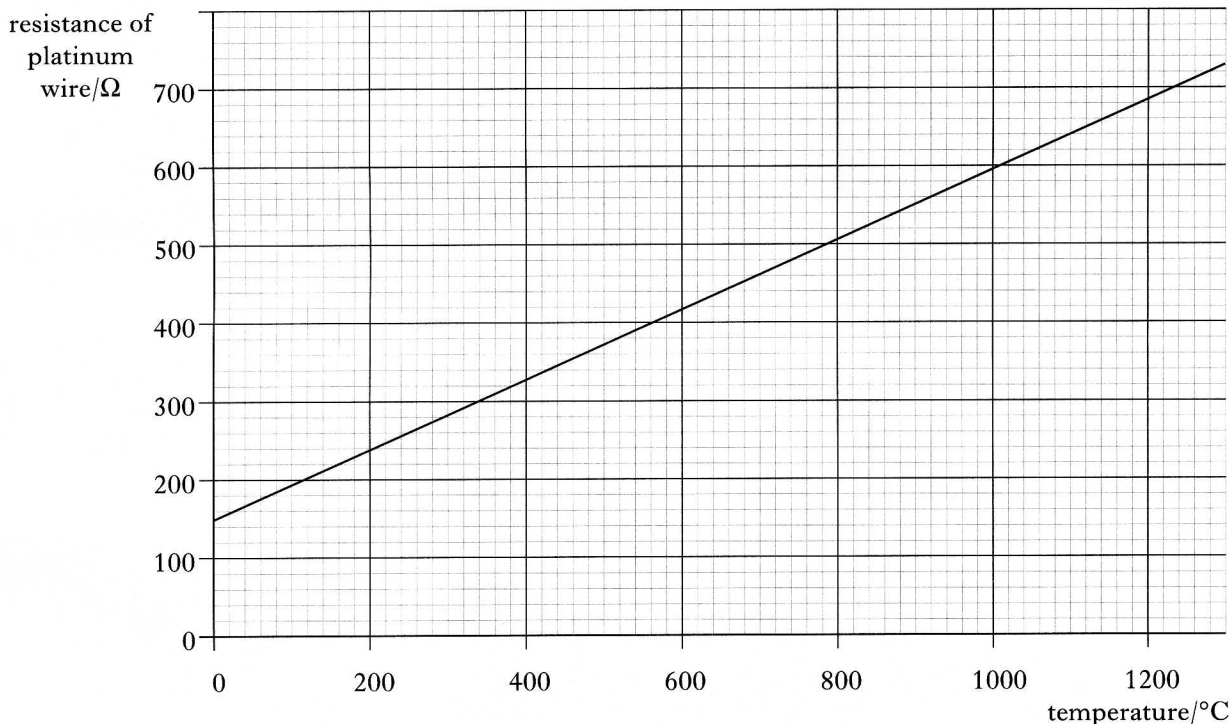

The temperature of the gas and the platinum wire is changed to 600 °C. The Wheatstone bridge is now out of balance.

- (i) What is the resistance of the platinum wire at 600 °C?  
 (ii) Calculate the p.d. across the 1.0 kΩ resistor.  
 (iii) Calculate the reading on the voltmeter.

6  
(9)

6. A particle accelerator increases the speed of protons by accelerating them between a pair of parallel metal plates, **A** and **B**, connected to a power supply as shown below.

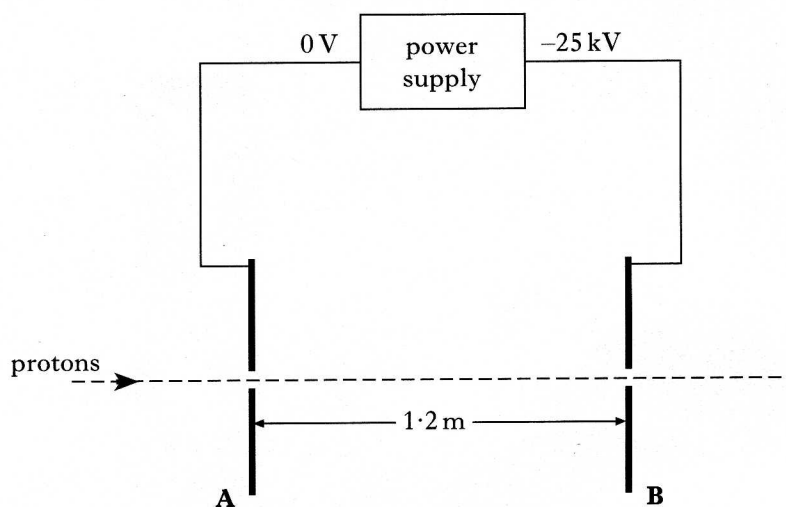

The potential difference between **A** and **B** is 25 kV.

- (a) Show that the kinetic energy gained by a proton between plates **A** and **B** is  $4.0 \times 10^{-15}$  J. 2
- (b) The kinetic energy of a proton at plate **A** is  $1.3 \times 10^{-16}$  J.  
Calculate the velocity of the proton on reaching plate **B**. 3
- (c) The plates are separated by a distance of 1.2 m.  
Calculate the force produced by the particle accelerator on a proton as it travels between plates **A** and **B**. 2
- (7)

7. A student is investigating the charging and discharging of a  $10\,000\ \mu\text{F}$  capacitor using the circuit shown below. The  $6\ \text{V}$  supply has negligible internal resistance.

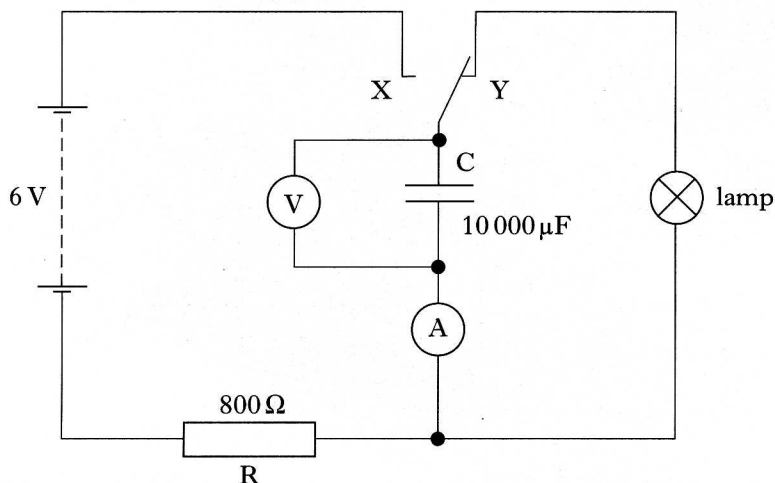

Initially the capacitor is uncharged and the switch is in position Y. The switch is moved to position X until the capacitor is fully charged and then finally back to position Y.

The graphs below show the p.d.  $V_C$  across the capacitor and the current  $I_C$  in the ammeter during this process.

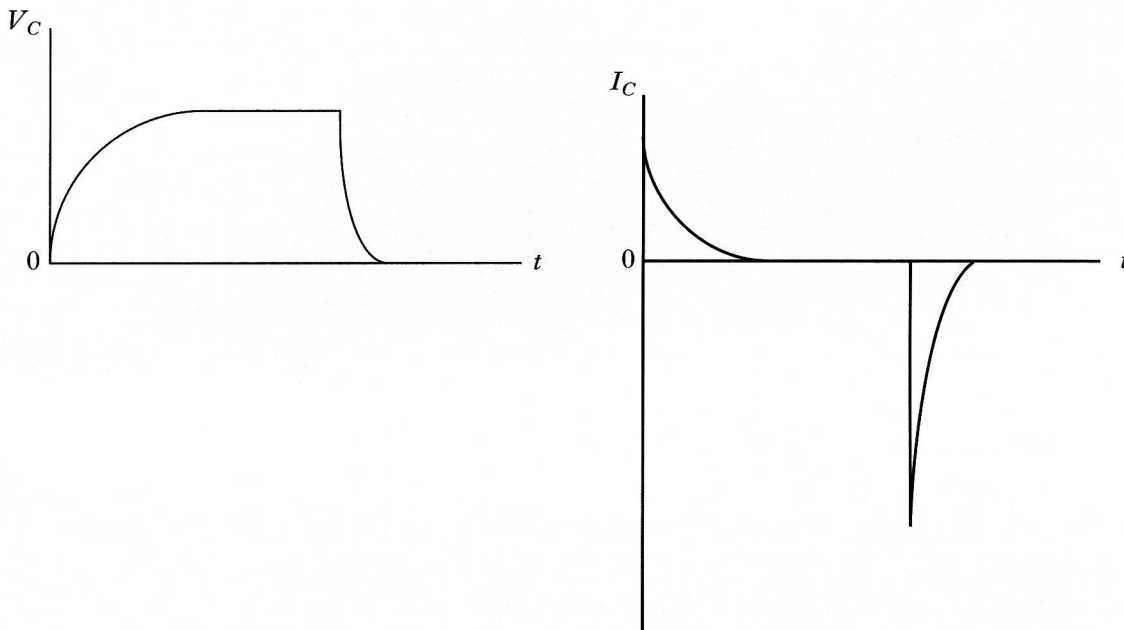

- (a) (i) State the value of the p.d. across the capacitor when it is fully charged.  
 (ii) Calculate the maximum current during the charging process.  
 (iii) Sketch a graph showing how the p.d. across resistor R varies with time during the charging process. Numerical values are not required. 4
- (b) The student deduces from the graph of current against time for the discharge that the resistance of the lamp is less than  $800\ \Omega$ .  
 Explain why the student's deduction is correct. 1
- (c) Calculate the energy stored in the capacitor when it is fully charged. 2

(7)

8. (a) An operational amplifier is connected in a circuit as shown below.

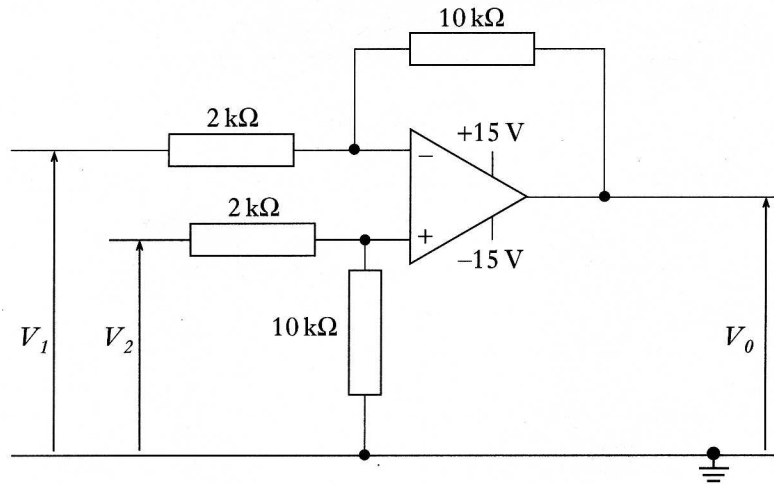

- (i) In what mode is the operational amplifier operating?
- (ii) The input voltage  $V_1$  is 0.3 V and input voltage  $V_2$  is 0.4 V.  
Calculate the output voltage  $V_0$ .

3

(b) A second operational amplifier is now connected as shown below.

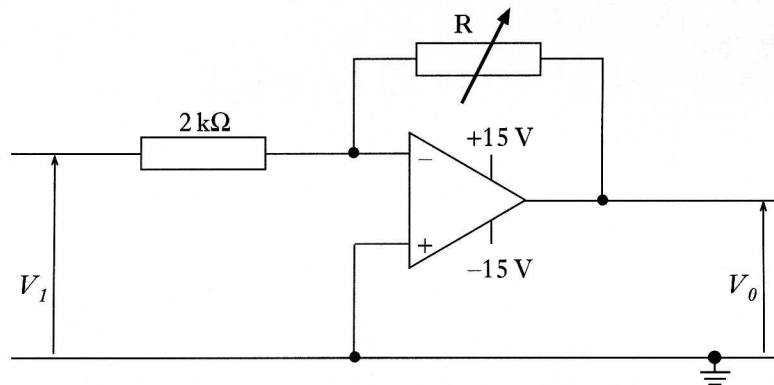

- (i) The input voltage  $V_1$  is 0.5 V and the output voltage  $V_0$  is -4.0 V.  
Calculate the resistance of R.
- (ii) The input voltage  $V_1$  is kept at 0.5 V. The resistance of R is gradually increased to 100 kΩ.  
Describe what happens to the output voltage  $V_0$ .

4  
(7)

9. (a) The word Laser is an acronym for “light amplification by the stimulated emission of radiation”.

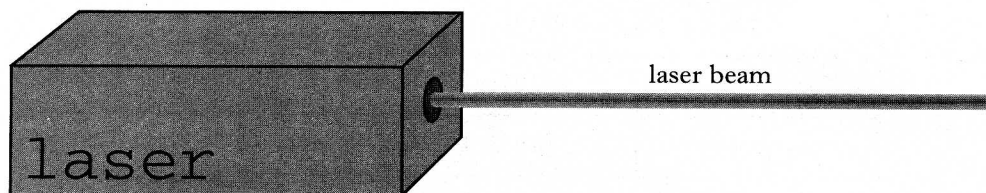

Describe what is meant by “stimulated emission” and describe how amplification is produced in a laser.

3

- (b) Infrared radiation from a laser is directed at a small cylinder of copper as shown below. The cylinder has a cross sectional area of  $1.25 \times 10^{-5} \text{ m}^2$ . The intensity of the laser beam at the surface of the cylinder is  $4.00 \times 10^5 \text{ W m}^{-2}$ .

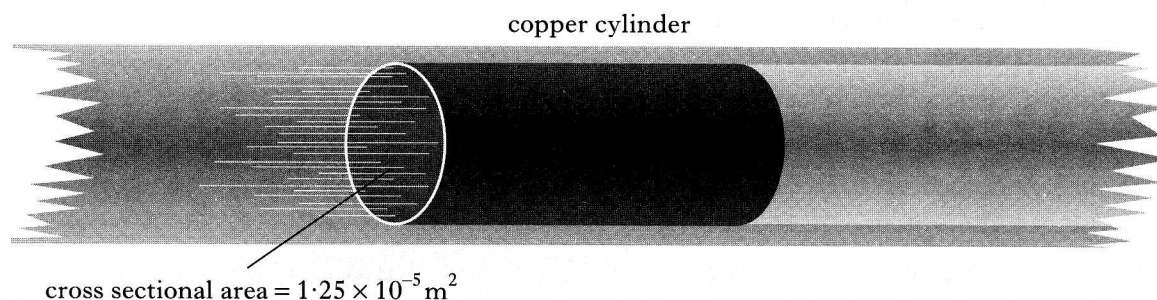

- (i) Show that the energy delivered to the cylinder in 100 seconds is 500 J.  
 (ii) The cylinder has a mass of  $1.12 \times 10^{-3} \text{ kg}$  and the initial temperature of the cylinder is 293 K.

Using information from the Data Sheet, show by calculation whether or not the 500 J of energy is sufficient to raise the temperature of the copper cylinder to its melting point.

7

(10)

[Turn over

10. In investigating the effect of different types of radiation on the human body, the data in the table below was obtained for one particular type of body tissue.

<i>Radiation</i>	<i>Absorbed Dose Rate</i>	<i>Quality Factor</i>
$\gamma$ -rays	$100 \mu\text{Gy h}^{-1}$	1
Fast neutrons	$400 \mu\text{Gy h}^{-1}$	10
$\alpha$ -particles	$50 \mu\text{Gy h}^{-1}$	20

- (a) Show, using the data in the table, which radiation is likely to be the most harmful to this tissue. 3
- (b) (i) The maximum permitted dose equivalent for this tissue is 5 mSv. Calculate the time the tissue can be exposed to fast neutrons without exceeding this limit.
- (ii) A sample of this tissue has a mass of 25 grams. How much energy will it absorb from fast neutrons in 2 hours? 5
- (c) The effect of radiation on tissue can be reduced by putting shielding material between the source of radiation and the tissue. The effectiveness of this shielding material can be described by the half-value thickness of the material.
- (i) Explain the meaning of "half-value thickness".
- (ii) The half-value thickness for a particular material is 7 mm. A block of this material of thickness 3.5 cm is inserted between the source and the tissue.
- What fraction of the radiation which is directed at the tissue is received by the tissue? 3

(11)

