

[3220/341]

1994

SCOTTISH CERTIFICATE OF EDUCATION

PHYSICS (REVISED)

Higher Grade—PAPER I

Friday, 13th May—9.30 a.m. to 11.00 a.m.

READ CAREFULLY

1. All questions should be attempted.
2. The following data may be required.

Speed of light in vacuum c	$3.00 \times 10^8 \text{ m s}^{-1}$	Planck's constant h	$6.63 \times 10^{-34} \text{ J s}$
Charge on electron e	$-1.60 \times 10^{-19} \text{ C}$	Mass of electron m_e	$9.11 \times 10^{-31} \text{ kg}$
Acceleration due to gravity g	9.8 m s^{-2}	Mass of proton m_p	$1.67 \times 10^{-27} \text{ kg}$

SECTION A (questions 1 to 30)

3. Check that the answer sheet is for Physics (Revised) Higher I (Section A).
4. Answer the questions numbered 1 to 30 on the answer sheet provided.
5. Fill in the details required on the answer sheet.
6. Rough working, if required, should be done only on this question paper, or on the first two pages of the answer book provided—NOT on the answer sheet.
7. For each of the questions 1 to 30 there is only ONE correct answer.
8. Instructions as to how to record your answers to questions 1–30 are given on page two.

SECTION B (questions 31 to 37)

9. Answer questions numbered 31 to 37 in the answer book provided.
10. Fill in the details on the front of the answer book.
11. Enter the question number clearly in the margin of the answer book beside each of your answers to questions 31 to 37.
12. Care should be taken NOT to give an unreasonable number of significant figures in the final answers to calculations.

SECTION A

For questions 1 to 30 in this section of the paper, an answer is recorded on the answer sheet by indicating the choice A, B, C, D or E by a stroke made in ink in the appropriate box of the answer sheet—see the example below.

EXAMPLE

The energy unit measured by the electricity meter in your home is the

- A ampere
- B kilowatt-hour
- C watt
- D coulomb
- E volt.

The correct answer to the question is B—kilowatt-hour. Record your answer by drawing a heavy vertical line joining the two dots in the appropriate box on your answer sheet in the column of boxes headed B. The entry on your answer sheet would now look like this:

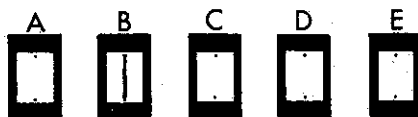

If after you have recorded your answer you decide that you have made an error and wish to make a change, you should cancel the original answer and put a vertical stroke in the box you now consider to be correct. Thus, if you want to change an answer D to an answer B, your answer sheet would look like this:

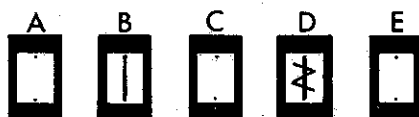

If you want to change back to an answer which has already been scored out, you should enter a tick (✓) to the RIGHT of the box of your choice, thus:

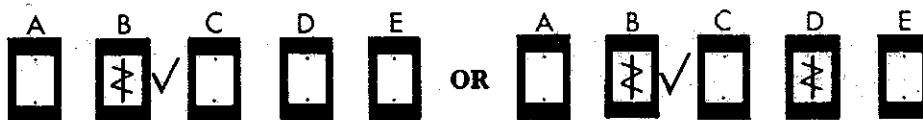

SECTION A

Answer questions 1–30 on the answer sheet.

1. Consider the following three statements made by pupils about scalars and vectors.

- I Scalars have direction only.
 - II Vectors have both size and direction.
 - III Speed is a scalar and velocity is a vector.
- Which statement(s) is/are true?

- A I only
- B I and II only
- C I and III only
- D II and III only
- E I, II and III

2. A golfer strikes a ball straight down the fairway.

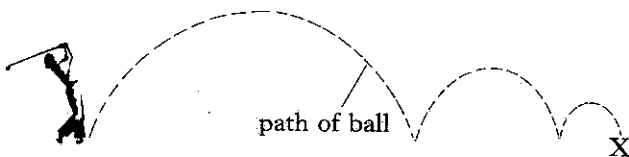

The ball bounces twice before stopping at point X.

Which of the following could be a graph of the **vertical** component of its velocity against time **after** it is struck?

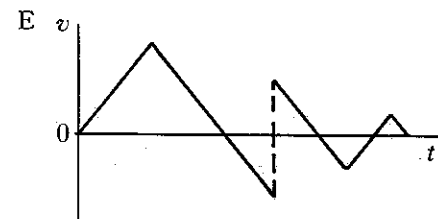
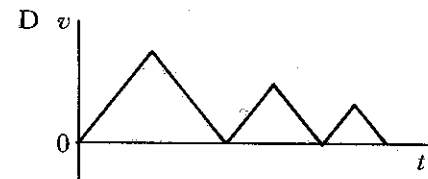
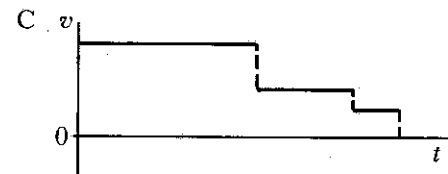
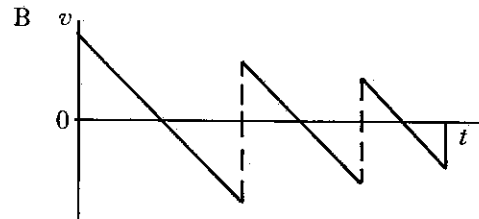
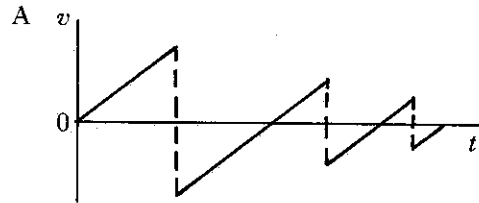

[Turn over

3. A car travelling at 30 m s^{-1} starts to brake when it is 50 m from a stationary lorry. The car moves in a straight line and manages to stop just before reaching the lorry.

What is the deceleration of the car, in m s^{-2} ?

- A 0.6
 B 4.5
 C 9
 D 10
 E 18
4. A lift is raised and lowered by means of a cable.

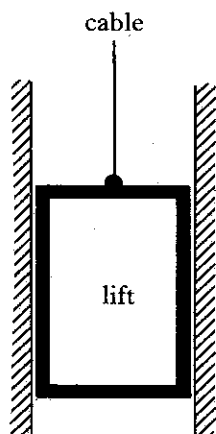

In which of the following situations is the tension in the cable greatest?

- A The lift is travelling upwards at a constant speed.
 B The lift is travelling downwards at a constant speed.
 C The lift is decelerating on the way down.
 D The lift is accelerating on the way down.
 E The lift is decelerating on the way up.

5. A car of mass 900 kg pulls a caravan of mass 400 kg along a straight, horizontal road with an acceleration of 2 m s^{-2} .

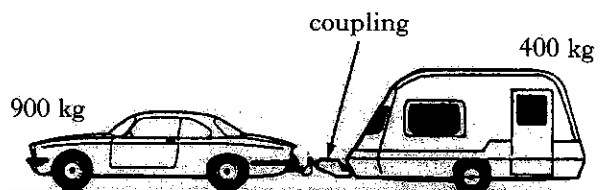

Assuming that the frictional forces are negligible, the tension in the coupling between the car and the caravan is

- A 400 N
 B 500 N
 C 800 N
 D 1800 N
 E 2600 N.
6. A cyclist free-wheels down a slope, inclined at 15° to the horizontal, at a constant velocity of 3 m s^{-1} .

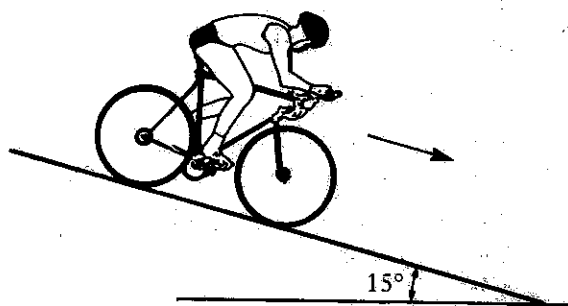

The combined mass of the rider and bicycle is 70 kg . If the value of the acceleration due to gravity is taken as 10 m s^{-2} , the total force of friction is

- A 181 N
 B 210 N
 C 362 N
 D 391 N
 E 676 N.

7. A force, which is applied in a straight line to an object, varies with time as shown in the following graph.

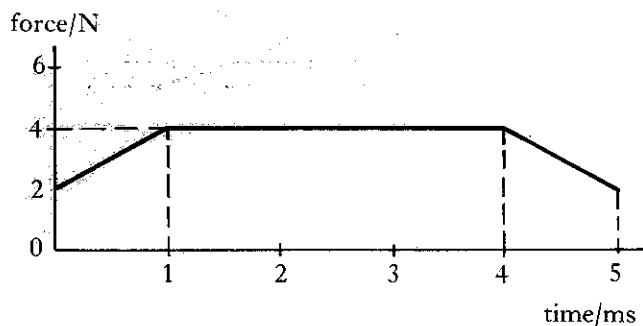

What is the total impulse given to the object by the force in this 5 millisecond time interval?

- A $8 \times 10^{-3} \text{ N s}$
 B $10 \times 10^{-3} \text{ N s}$
 C $15 \times 10^{-3} \text{ N s}$
 D $18 \times 10^{-3} \text{ N s}$
 E $20 \times 10^{-3} \text{ N s}$
8. A shell of mass 5 kg is travelling horizontally with a speed of 200 m s^{-1} when it explodes into two parts. One part of mass 3 kg continues in the original direction with a speed of 100 m s^{-1} . The other part also continues in this same direction. Its speed will be
- A 150 m s^{-1}
 B 200 m s^{-1}
 C 300 m s^{-1}
 D 350 m s^{-1}
 E 700 m s^{-1} .

9. An object of mass 4 kg falls from a considerable height in an area where the acceleration due to gravity is 10 m s^{-2} .

The velocity-time graph for the first 35 seconds of its motion is as follows.

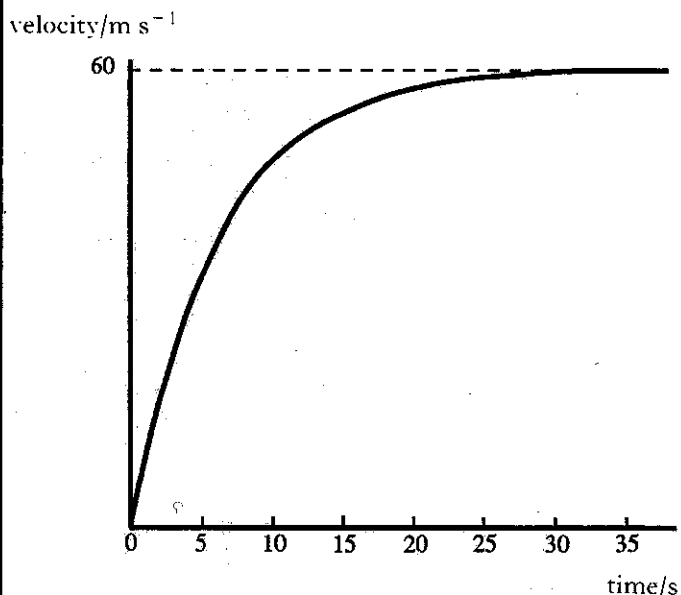

Which row in the following table could give the frictional forces acting on the object at 4 seconds, 8 seconds and 32 seconds?

	Force at 4 s	Force at 8 s	Force at 32 s
A	0 N	30 N	40 N
B	40 N	30 N	0 N
C	40 N	40 N	40 N
D	20 N	30 N	40 N
E	0 N	0 N	40 N

[Turn over

10. After a car has been parked in the sun for some time, it is found that the pressure in the tyres has increased. This is because

- A the volume occupied by the air molecules in the tyres has increased
- B the force produced by the air molecules in the tyres acts over a smaller area
- C the average spacing between the air molecules in the tyres has increased
- D the increased temperature has made the air molecules in the tyres expand
- E the air molecules in the tyres are moving with greater kinetic energy.

11. In the arrangement shown below, 2 C of positive charge is moved from plate S, which is at a potential of 250 V, to plate T, which is at a potential of 750 V.

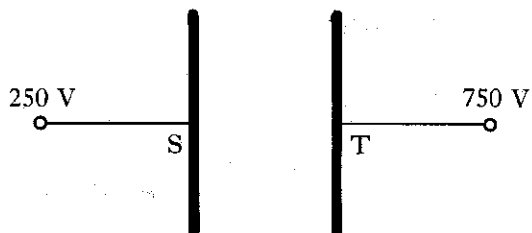

How much energy is required to move this charge from plate S to plate T?

- A 0.004 J
- B 250 J
- C 500 J
- D 1000 J
- E 1500 J

12. In which of the following arrangements of resistors is the resistance between X and Y the same?

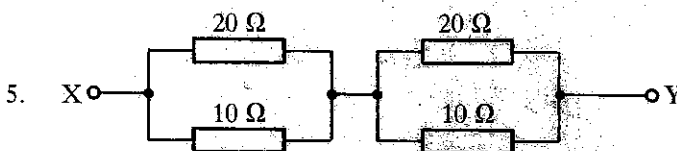
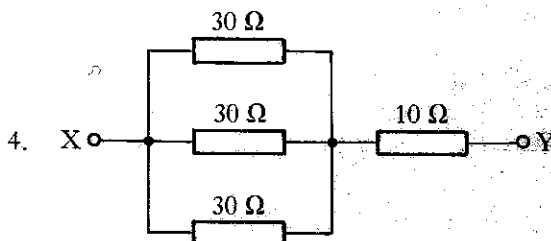
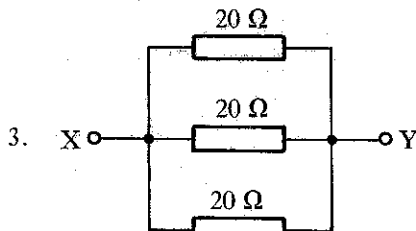
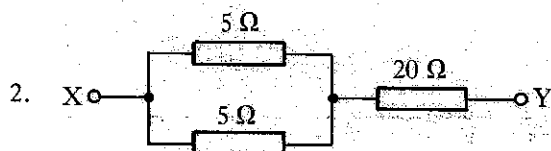
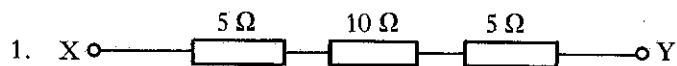

- A 1 and 2 only
- B 1 and 3 only
- C 1 and 4 only
- D 1, 2 and 4 only
- E 1, 3 and 5 only

13. The current delivered by the battery in the following circuit is 3 A.

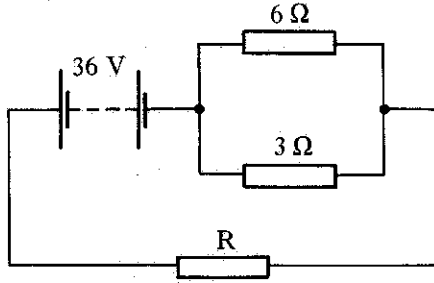

Assuming that the battery has negligible internal resistance, the resistance of resistor R is

- A 3 Ω
 B 4 Ω
 C 10 Ω
 D 12 Ω
 E 18 Ω
14. A battery of e.m.f. 12 V and internal resistance 1 Ω is connected across a 2 Ω resistor, as shown in the circuit below.

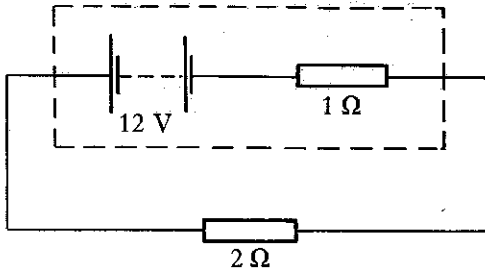

Which row in the following table shows the correct values for current, terminal potential difference and lost volts in this circuit?

	Current/A	t.p.d./V	lost volts/V
A	4	4	8
B	4	8	4
C	6	4	8
D	6	8	4
E	12	8	4

15. In the following Wheatstone bridge circuit, the reading on the voltmeter is zero when the resistance R_v of the variable resistor is set at 1 kΩ.

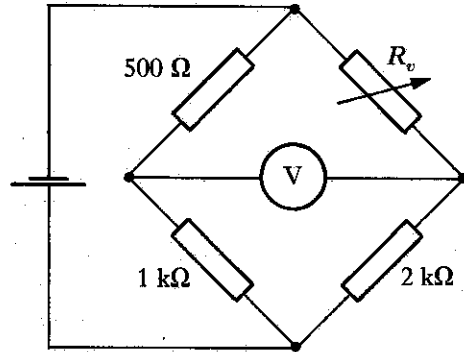

Which of the following would best represent the shape of a graph of the voltmeter reading V against the resistance R_v as it is varied between 990 Ω and 1010 Ω?

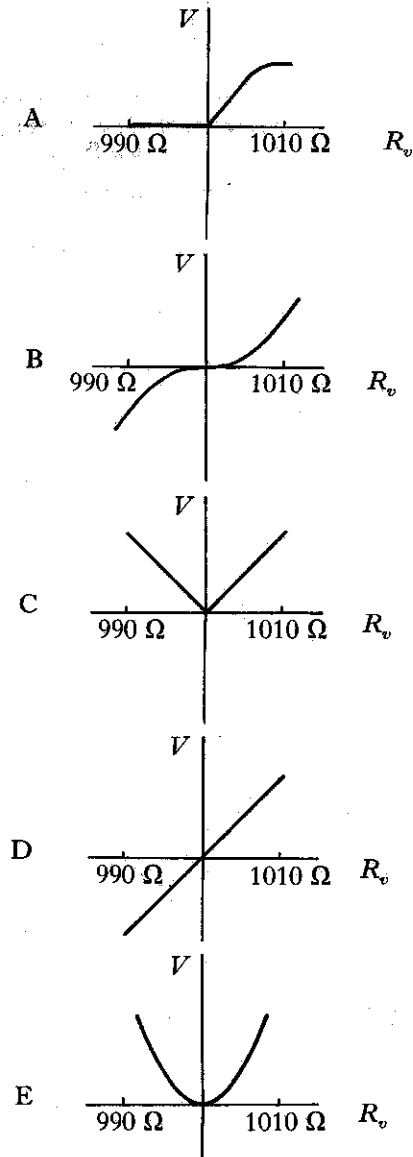

16. The circuit in the diagram below is used for charging a capacitor.

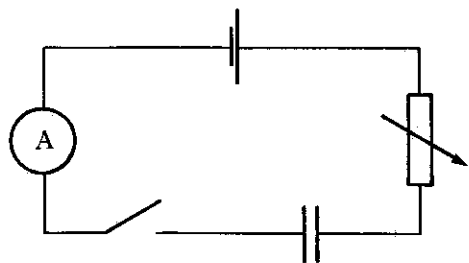

The switch is closed and the capacitor charges up. The variation of current I with time t for this circuit is shown in the following graph.

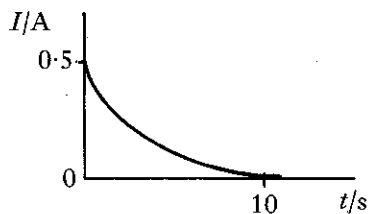

The capacitor is discharged and the value of the variable resistor is **increased**. The experiment is then repeated. Which of the following graphs shows the correct variation of current with time?

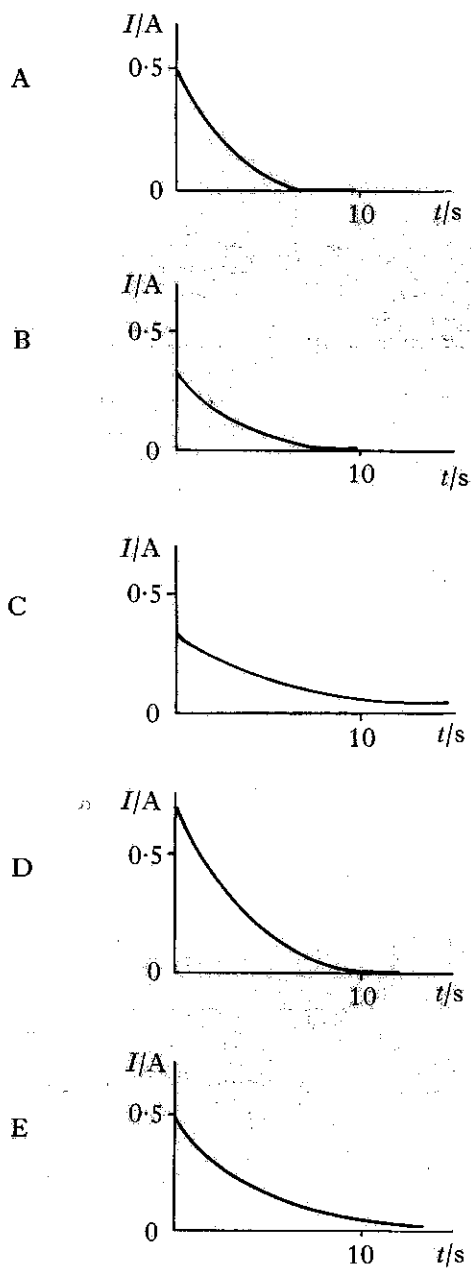

17. In the graph below, the shaded area is used to calculate the work done in charging a capacitor.

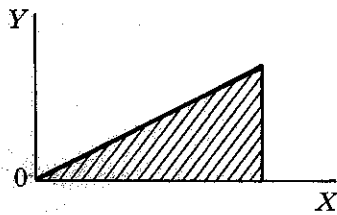

What should be the labels on the X and Y axes?

	X-axis label	Y-axis label
A	charge	potential difference
B	current	potential difference
C	charge	time
D	current	time
E	current	charge

18. An immersion heater can be operated either from an a.c. supply or a d.c. supply. The graph below represents the a.c. supply voltage.

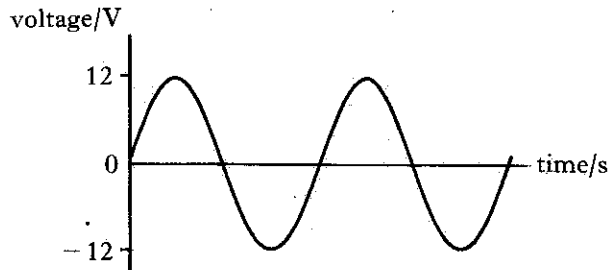

What d.c. supply voltage would produce the same rate of heating from this heater?

- A 6 V
- B $\frac{12}{\sqrt{2}}$ V
- C 12 V
- D $12\sqrt{2}$ V
- E 24 V

19. Two logic gates are connected together in the following way.

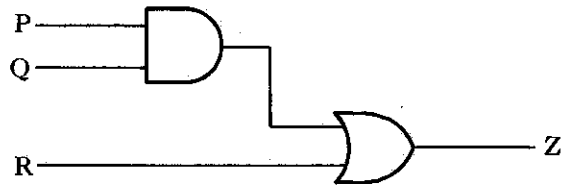

Pulse waveforms are applied to inputs P, Q and R as follows.

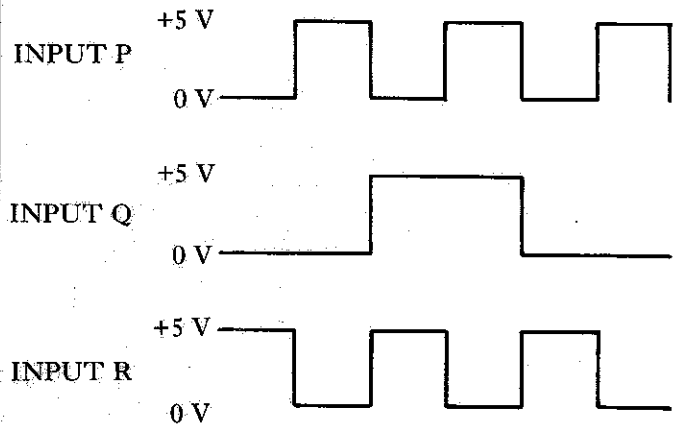

Which of the following shows the output pulse waveform at Z?

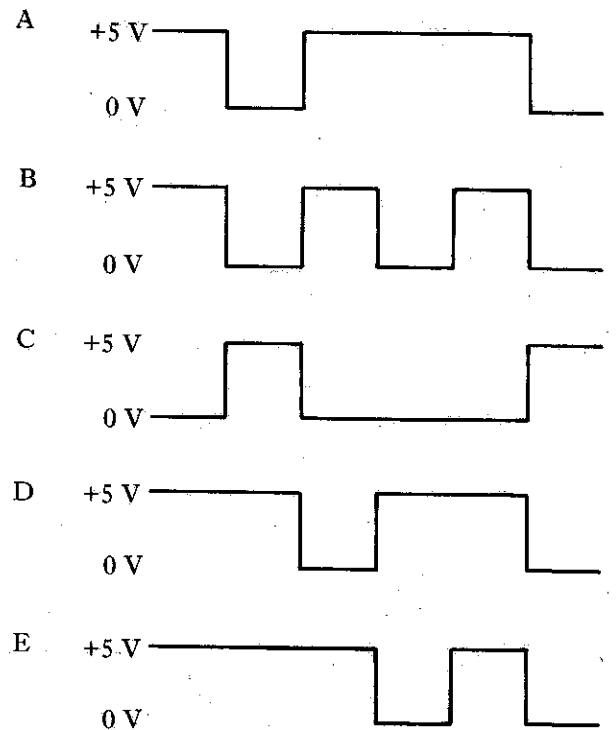

20. The circuit below is used to generate square waves.

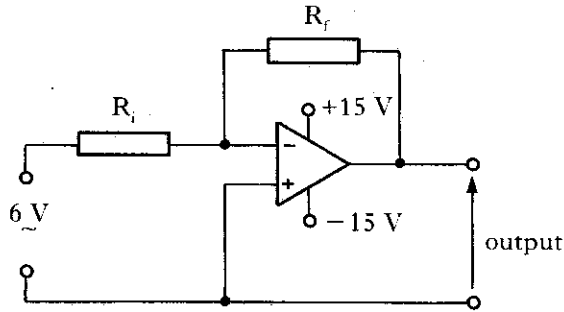

Which values for resistors R_1 and R_f will produce an approximately square wave output?

	R_1	R_f
A	1 k Ω	10 k Ω
B	5 k Ω	10 k Ω
C	10 k Ω	10 k Ω
D	10 k Ω	5 k Ω
E	10 k Ω	1 k Ω

21. A ray of light travels with speed v_1 through medium 1 and then passes into another medium 2, where it travels at speed v_2 .

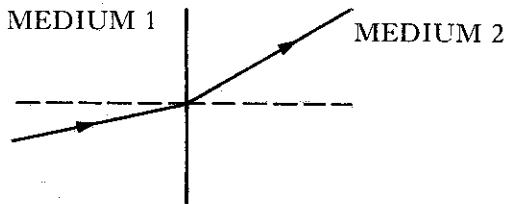

The refractive indices for medium 1 and medium 2 are n_1 and n_2 respectively.

Which row in the following table correctly compares the speeds and refractive indices for each medium?

	Speed of light	Refractive Index
A	v_2 is less than v_1	n_2 is less than n_1
B	v_2 is the same as v_1	n_2 is less than n_1
C	v_2 is the same as v_1	n_2 is greater than n_1
D	v_2 is greater than v_1	n_2 is less than n_1
E	v_2 is greater than v_1	n_2 is greater than n_1

22. A pupil sets up the apparatus shown below to investigate the relationship between the angle of incidence (i) and the angle of refraction (r) for a ray of light passing from air into glass.

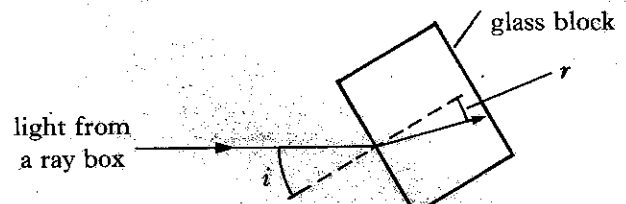

The pupil plots a graph of $\sin i$ against $\sin r$.

Which graph shows the correct relationship between $\sin i$ and $\sin r$?

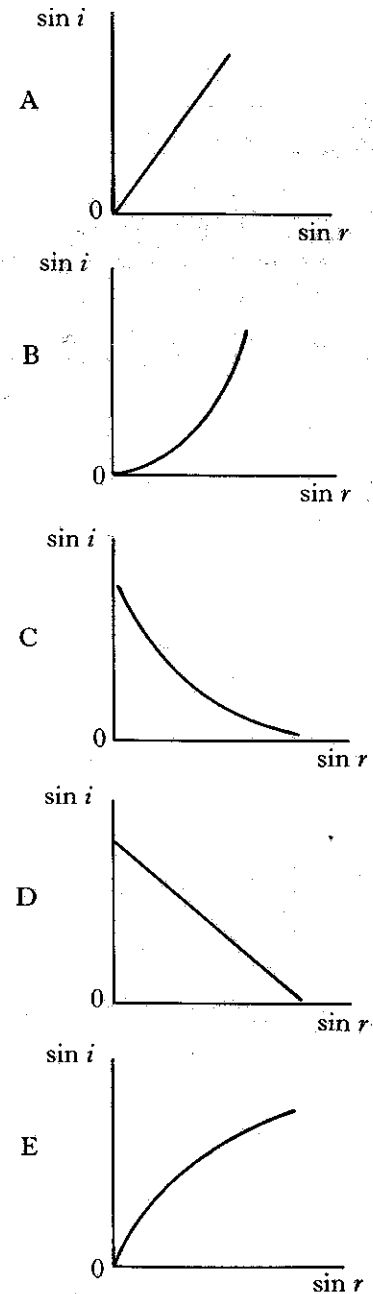

23. A ray of monochromatic light, travelling in air, strikes the side of a rectangular block of glass of refractive index 1.7, as shown below.

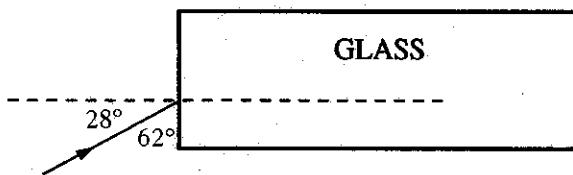

Which of the following diagrams shows correctly the subsequent path of the ray?

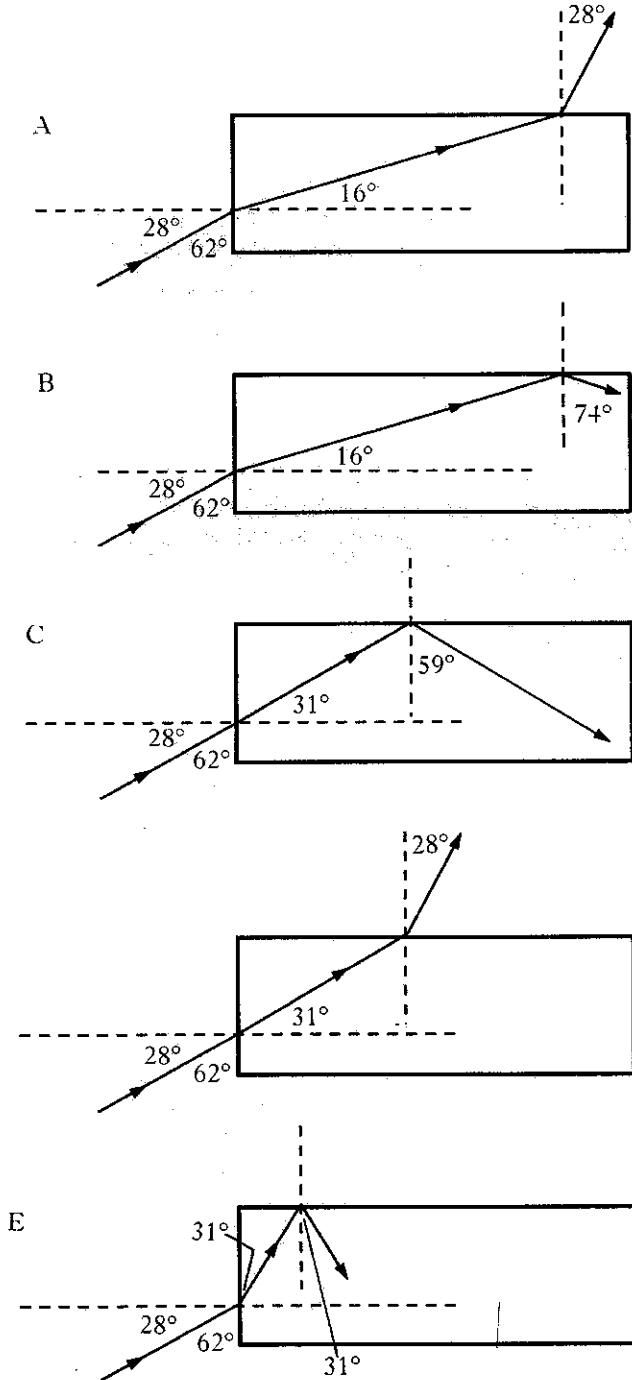

24. Monochromatic light of wavelength λ passes through a grating and produces a pattern of bright maxima on a screen. The separation of lines on the grating is d and the grating is at a distance L from the screen. Which of the following pairs of changes will **always** produce an **increase** in the spacing of the maxima on the screen?

A	increase L	increase d
B	increase λ	increase d
C	decrease L	decrease λ
D	increase L	decrease λ
E	increase λ	decrease d

25. An experiment is carried out to investigate the relationship between the light intensity I from a point source and the distance d from the source. The experiment is done in a darkened room and a meter connected to a light sensor indicates the intensity, as shown below.

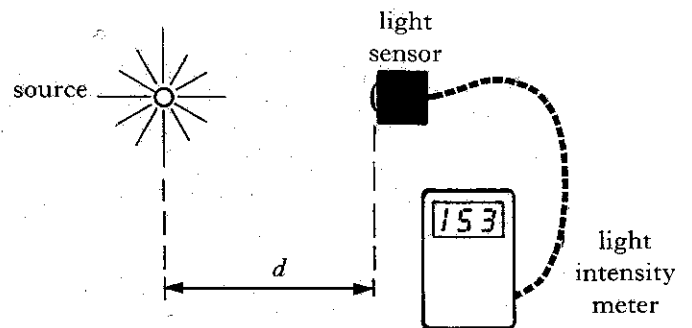

Which of the following expressions will give an approximately constant value?

- A $I \times d$
 B $I \times d^2$
 C $\frac{I}{d}$
 D $\frac{I}{d^2}$
 E $I \times \sqrt{d}$

26. A student makes a note of the following statements after a lesson about photoelectric emission.

- I Photoelectric emission from a metal occurs only if the frequency of the incident radiation is greater than the threshold frequency.
- II The threshold frequency depends on the metal from which photoemission takes place.
- III If the frequency of the incident radiation is less than the threshold frequency, increasing its intensity will cause photoemission.

Which of the above statements is/are correct?

- A I only
- B II only
- C I and II only
- D II and III only
- E I, II and III
27. The photon energies for three different radiations are as follows.

Radiation 1: 2.78×10^{-19} J

Radiation 2: 4.97×10^{-19} J

Radiation 3: 6.35×10^{-19} J

Which one of the following is true?

- A The wavelength of radiation 1 is longer than that of radiation 2.
- B The wavelength of radiation 3 is longer than that of radiation 2.
- C The frequency of radiation 1 is higher than that of radiation 2.
- D The frequency of radiation 1 is higher than that of radiation 3.
- E The frequency of radiation 2 is higher than that of radiation 3.
28. A student reads the following passage in a physics dictionary.

"... a solid state device in which positive and negative charge carriers are produced by the action of light on a p-n junction."

The passage describes a

- A light emitting diode
- B laser
- C capacitor
- D photodiode
- E thermistor.

29. For the nuclear disintegration described below, which row of the table shows the correct values of x , y and z ?

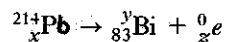

	x	y	z
A	84	214	1
B	83	210	4
C	85	214	2
D	82	214	-1
E	82	210	-1

30. Three materials X, Y and Z are used as gamma ray absorbers. They have half-value thicknesses of 2 cm, 4 cm and 8 cm respectively.

Gamma rays of intensity I strike the left side of this "sandwich" composed of X, Y and Z.

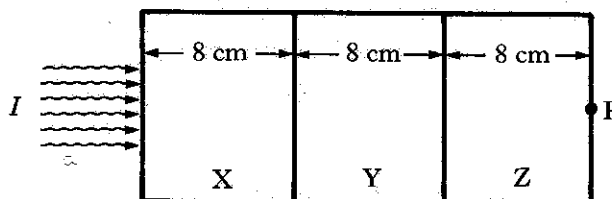

The intensity at point P, on the right side of the "sandwich", will be

- A $\frac{I}{8}$
- B $\frac{I}{16}$
- C $\frac{I}{32}$
- D $\frac{I}{64}$
- E $\frac{I}{128}$

SECTION B

Write your answers to Questions 31–37 in the answer book.

Marks

31. The velocity–time graph shown below is for an object moving with constant acceleration a .

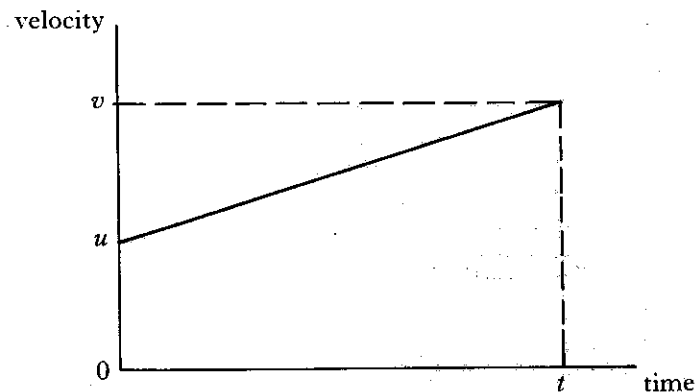

Show that during the time interval t the object moves through a displacement s given by

$$s = ut + \frac{1}{2} at^2.$$

2

32. The apparatus in the diagram below may be used to measure the density of air.

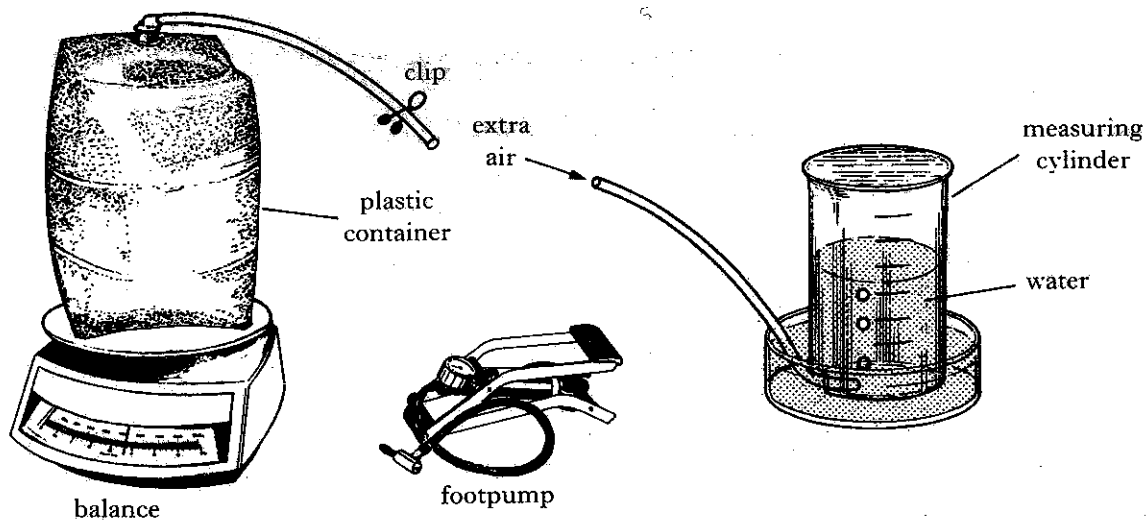

Using the footpump, extra air is pumped into the container. This extra air is released into the measuring cylinder as shown above and its volume measured.

The following measurements are recorded.

mass of container full of air	=	362.00 g
mass of container with extra air	=	363.86 g
volume of air released	=	1687.00 cm ³

What value do these results give for the density of air in kg m⁻³?

3

[Turn over

33. Liquid nitrogen changes to its gaseous state at a temperature of $-196\text{ }^{\circ}\text{C}$.

(a) What is this temperature in kelvin?

(b) Explain why a temperature of 0 kelvin is described as “the absolute zero of temperature”.

3

34. The circuit diagram for an **ideal** op-amp connected in the inverting mode is shown below.

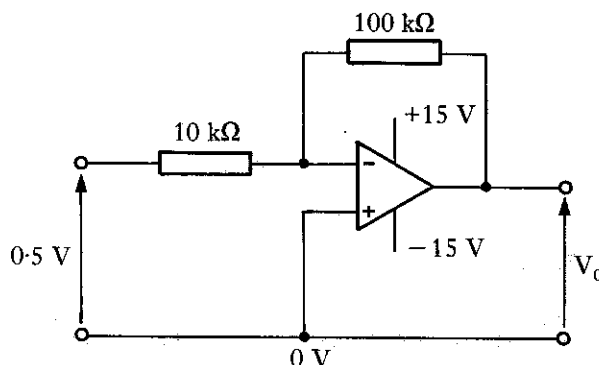

(a) What is the potential at the inverting input?

(b) What is the value of the current in the input resistor?

3

35. Loudspeakers 1 and 2 are both connected to the same signal generator which is set to produce a 1 kHz signal.

Loudspeaker 1 is switched on but loudspeaker 2 is switched off.

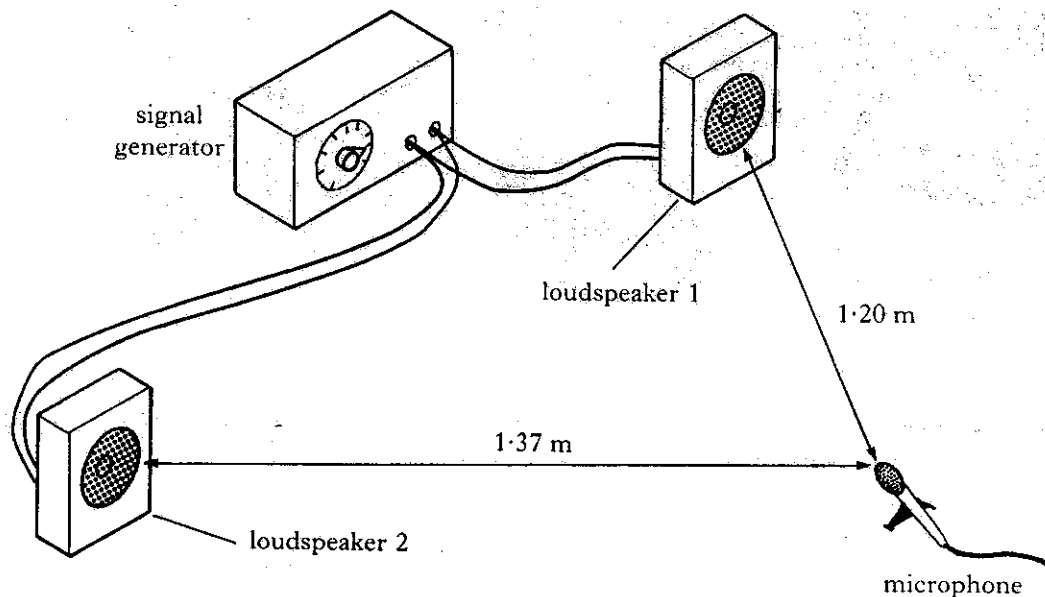

State **and** explain what happens to the amplitude of the signal picked up by the microphone when loudspeaker 2 is switched on.

Your explanation should include a calculation using the value of the speed of sound in air as 340 m s^{-1} .

3

36. (a) Materials may be classified as “conductors”, “semiconductors” and “insulators”.

Give an example of a material from each of these groups.

(b) An electronics textbook states that

“... n-type semiconductor material is formed by doping a pure semiconductor with impurity atoms.”

What is meant by the term “n-type” semiconductor material?

3

37. Energy is produced within the Sun by fusion reactions.

(a) State what is meant by a fusion reaction.

(b) Explain briefly why a fusion reaction releases energy.

3

[END OF QUESTION PAPER]