

Resistance

Resistance



Georg Simon Ohm
1789-1854

Resistance

Resistance is anything that will **RESIST** a current. It is measured in Ohms, a unit named after me.



Georg Simon Ohm
1789-1854

Resistance

Resistance is anything that will **RESIST** a current. It is measured in Ohms, a unit named after me.



Georg Simon Ohm
1789-1854

The resistance of a component can be calculated using Ohm's Law:

Resistance

Resistance is anything that will **RESIST** a current. It is measured in Ohms, a unit named after me.



Georg Simon Ohm
1789-1854

The resistance of a component can be calculated using Ohm's Law:

$$\text{Resistance (in } \Omega \text{)} = \frac{\text{Voltage (in V)}}{\text{Current (in A)}}$$

Resistance

Resistance is anything that will **RESIST** a current. It is measured in Ohms, a unit named after me.



Georg Simon Ohm
1789-1854

The resistance of a component can be calculated using Ohm's Law:

$$\text{Resistance (in } \Omega) = \frac{\text{Voltage (in V)}}{\text{Current (in A)}}$$

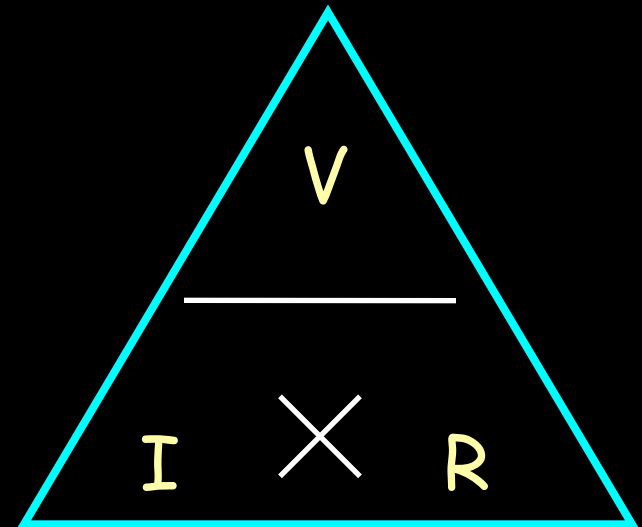

An example question:

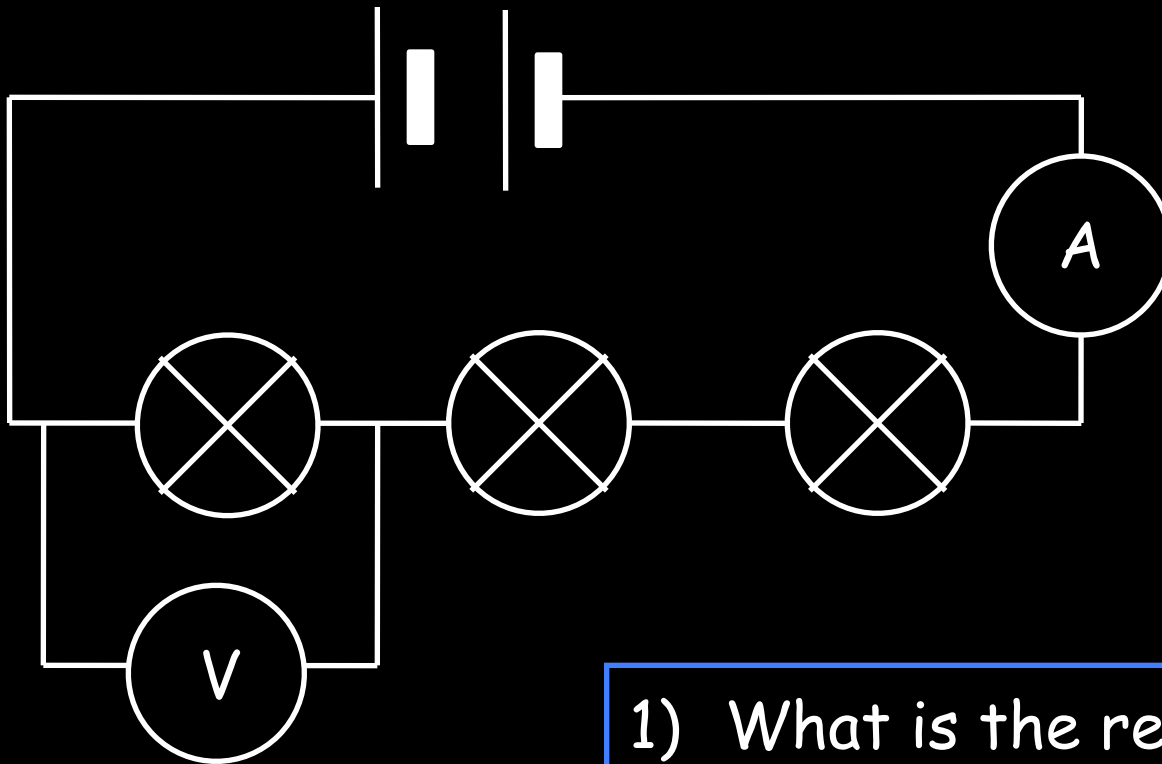

Ammeter
reads 2A

Voltmeter
reads 10V

- 1) What is the resistance of this bulb?
- 2) Assuming all the bulbs are the same what is the total resistance in this circuit?

More examples...

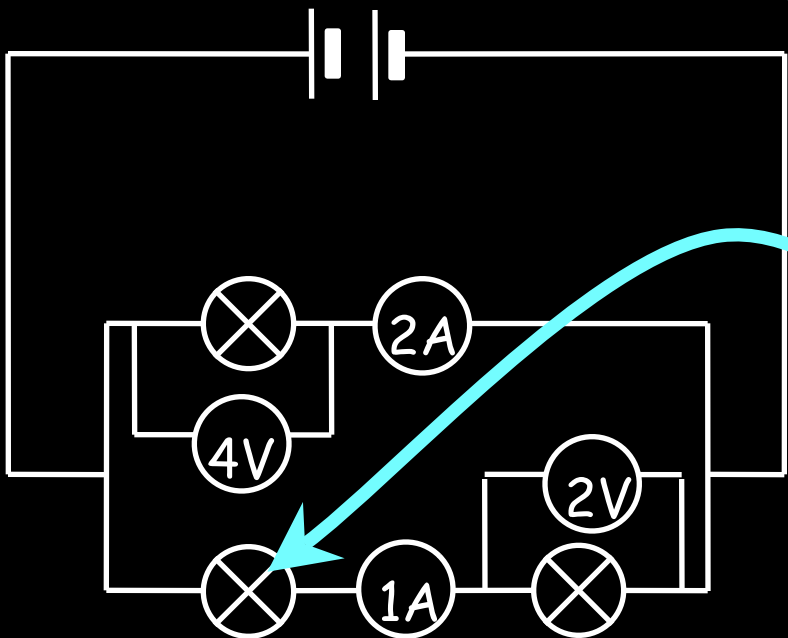
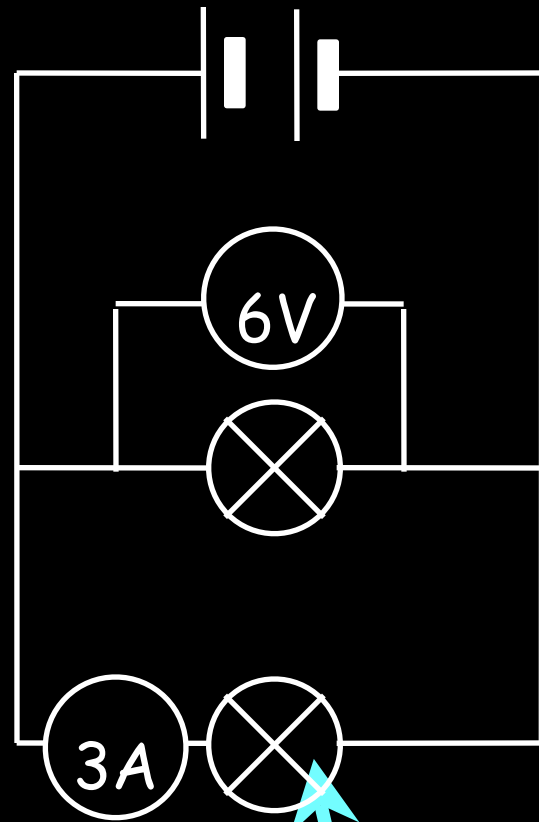
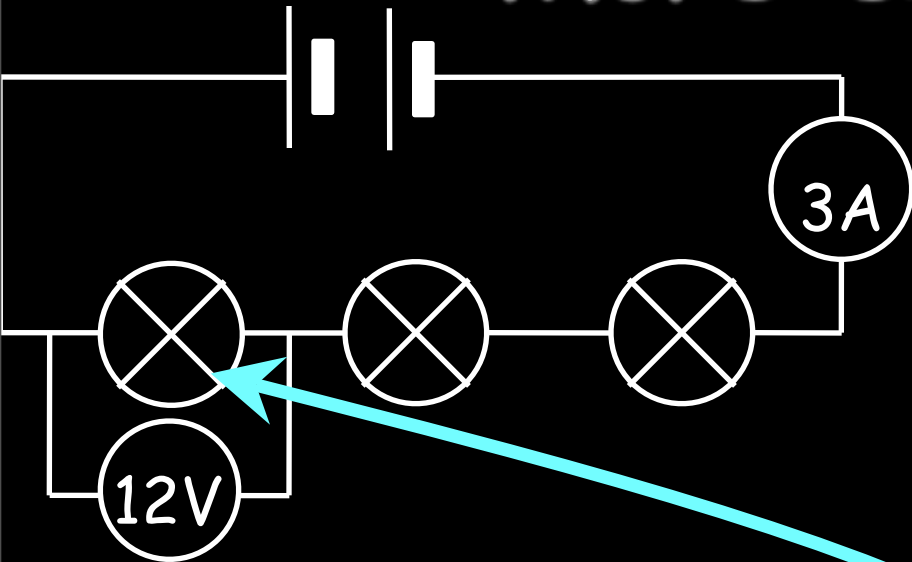

What is the resistance of these bulbs?

Current-voltage graphs

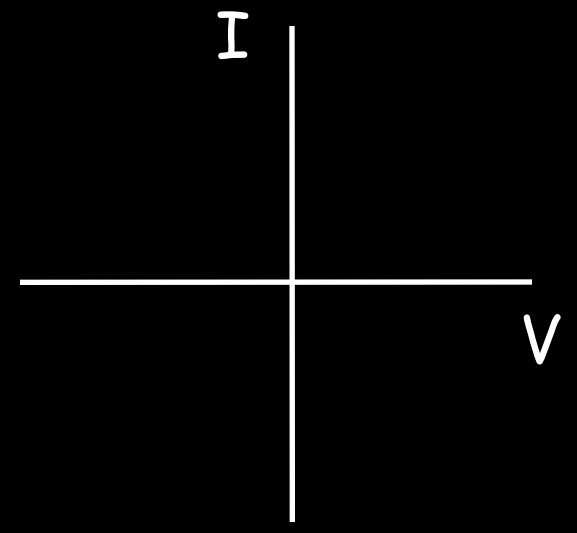
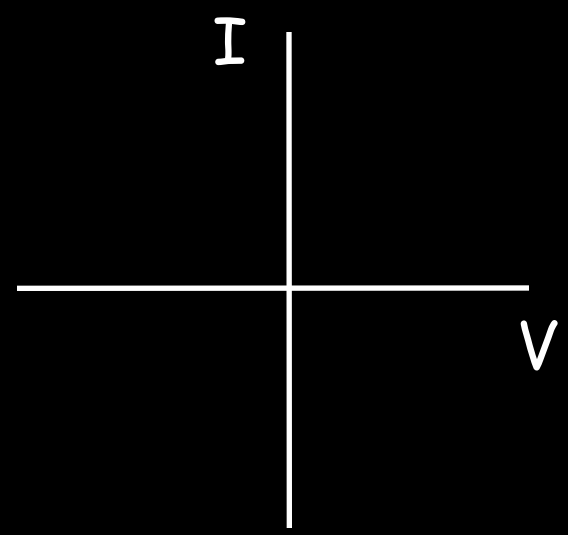
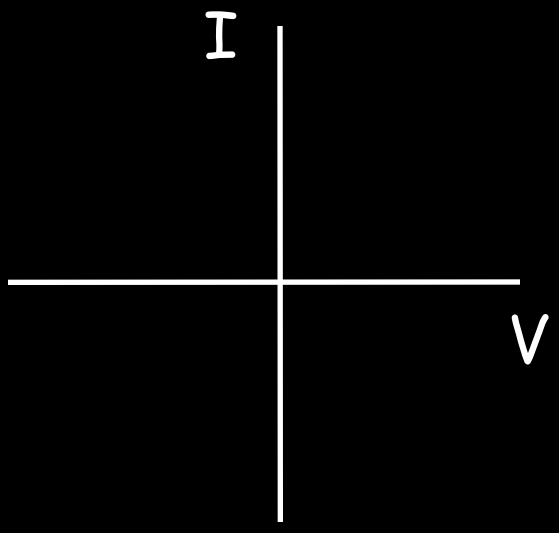

Current-voltage graphs

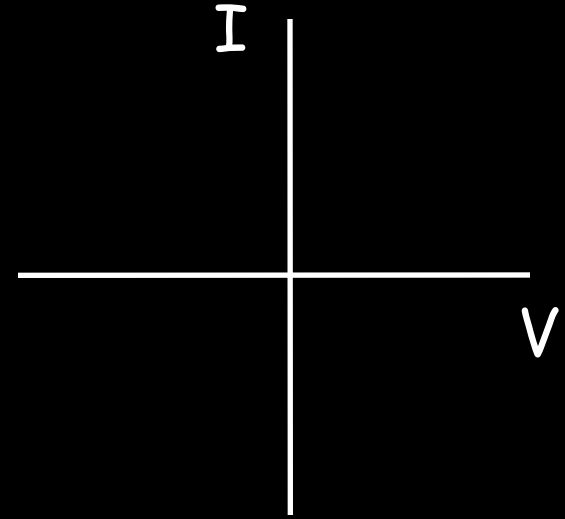
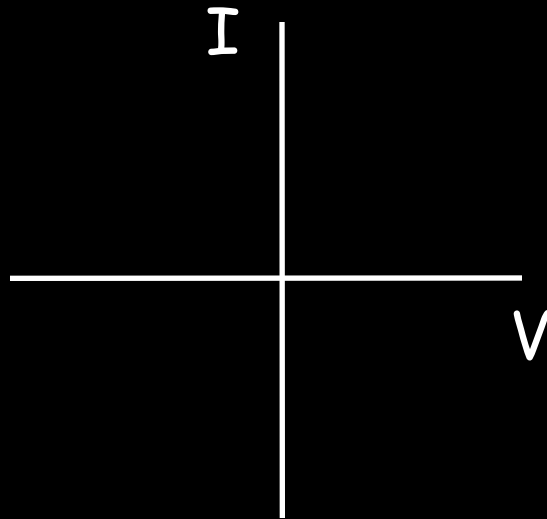
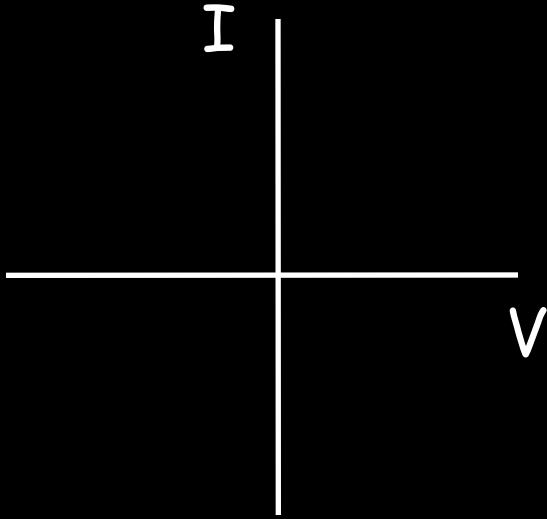

Explain the shape of each graph

Current-voltage graphs

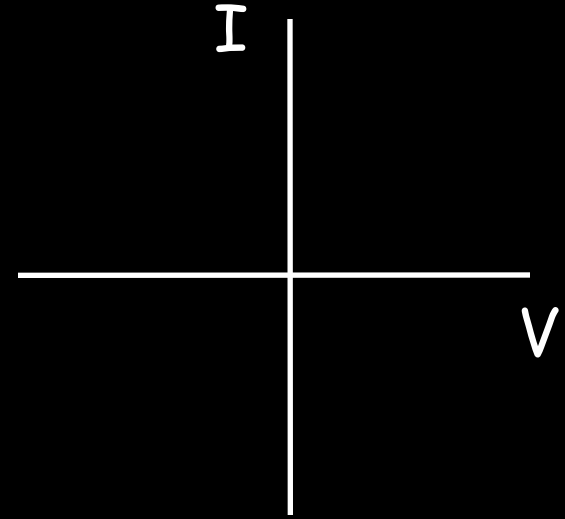
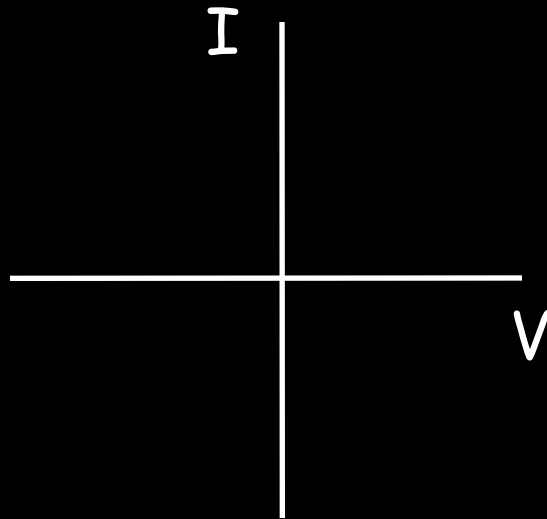
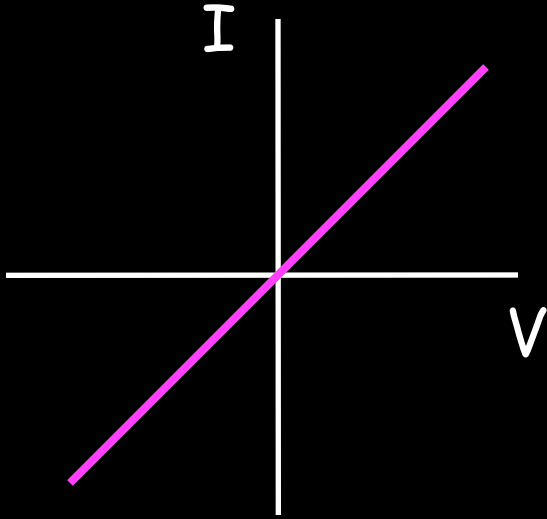

Explain the shape of each graph

Current-voltage graphs

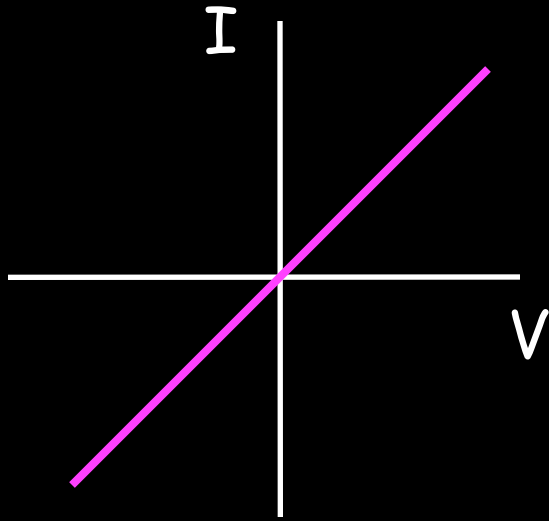

1. Resistor

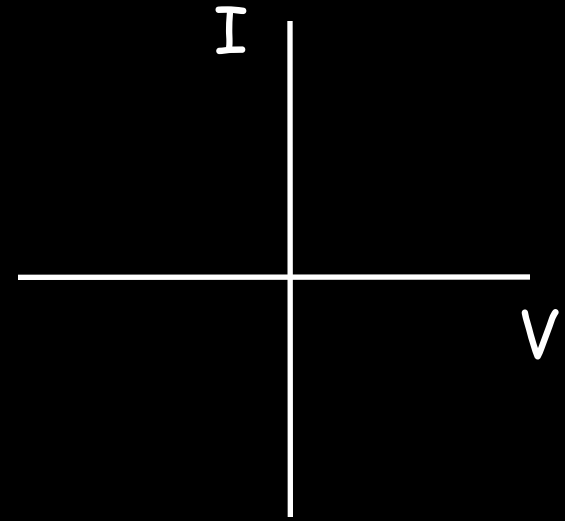
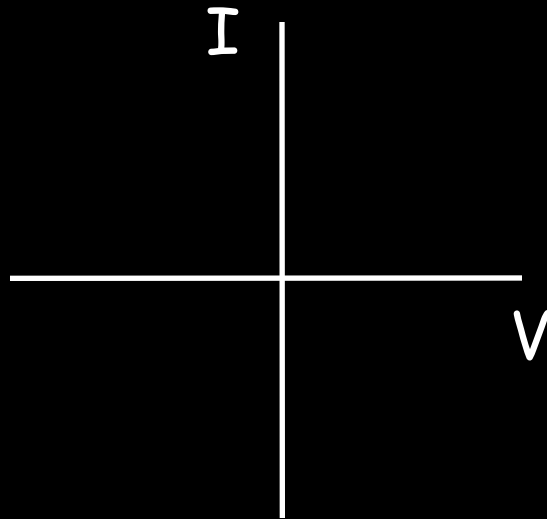

Explain the shape of each graph

Current-voltage graphs

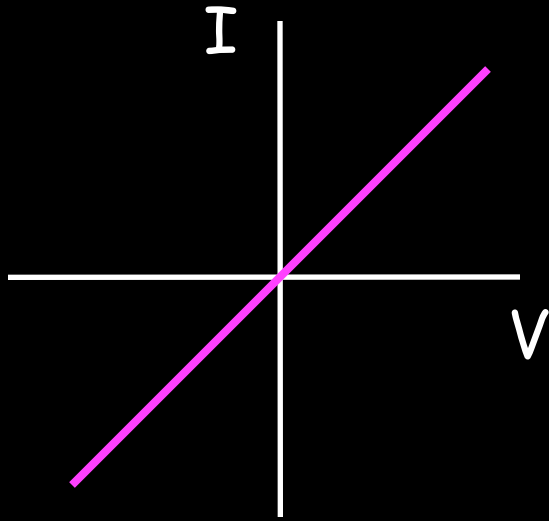

1. Resistor

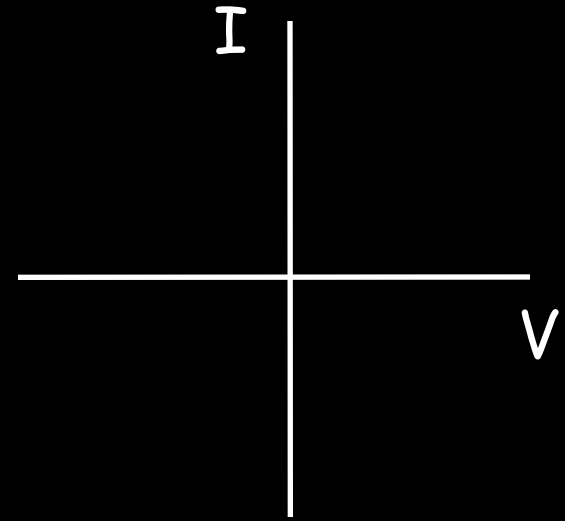
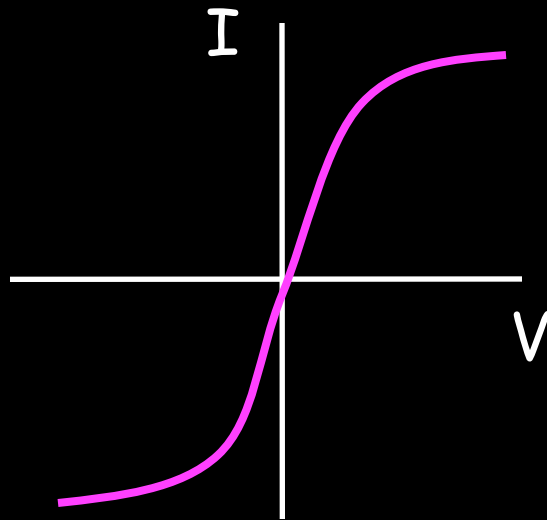

Explain the shape of each graph

Current-voltage graphs

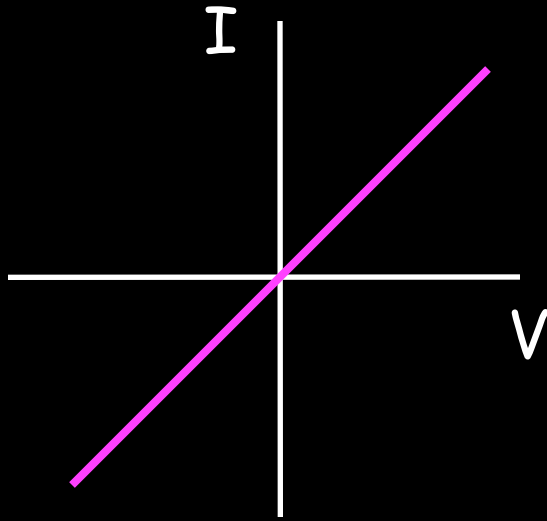

1. Resistor

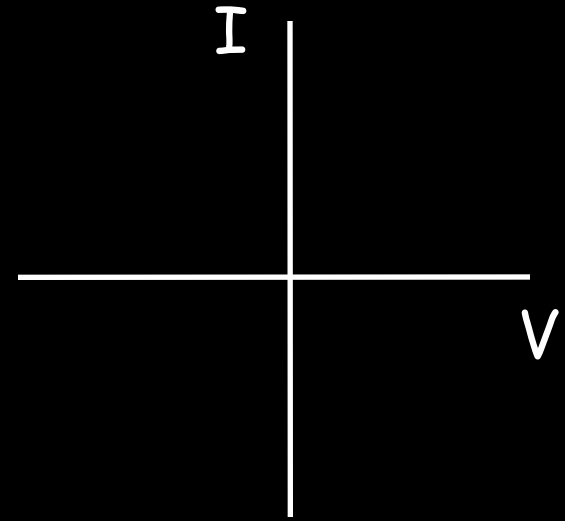
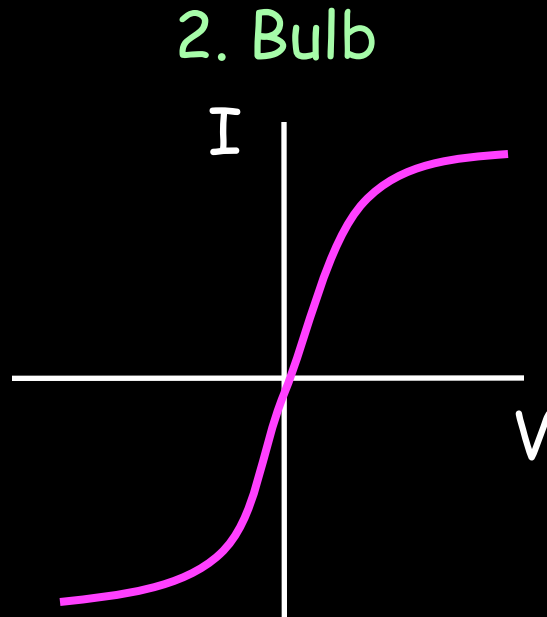

Explain the shape of each graph

Current-voltage graphs

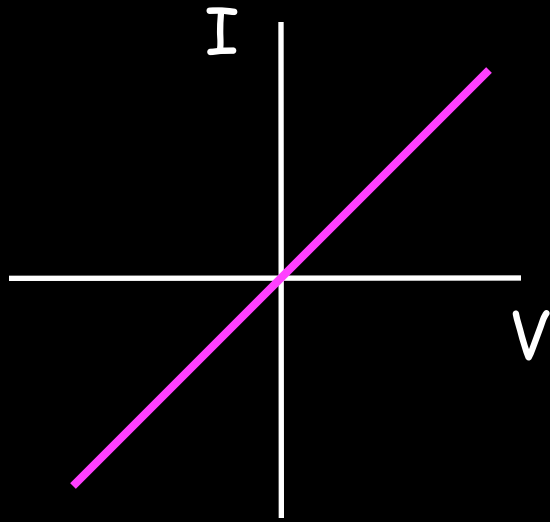

1. Resistor

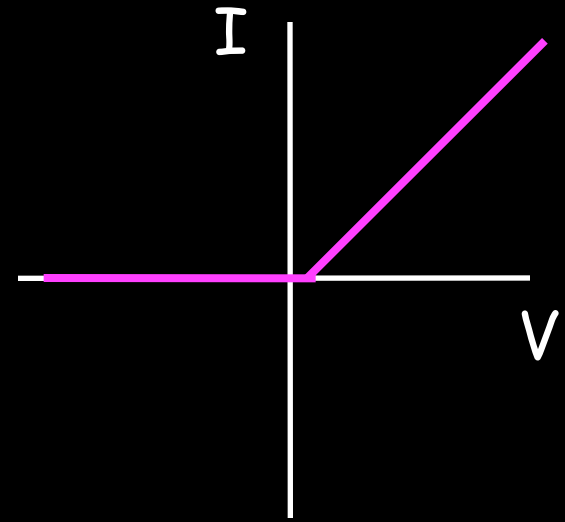
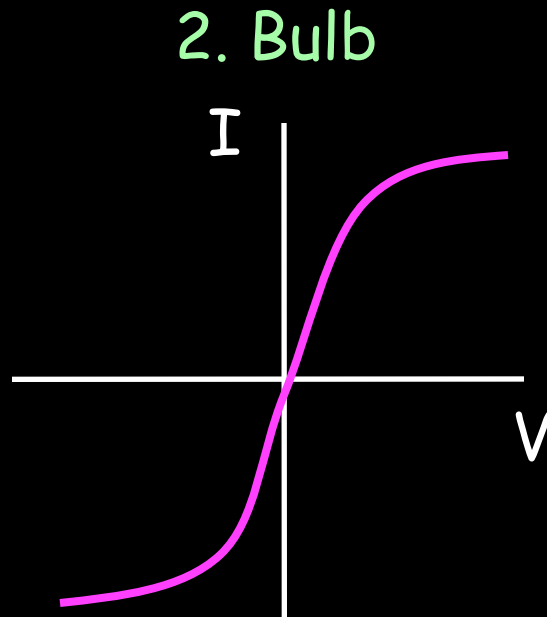

Explain the shape of each graph

Current-voltage graphs

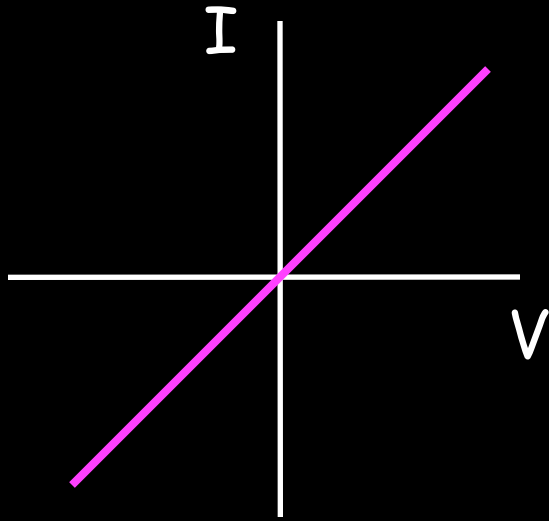

1. Resistor

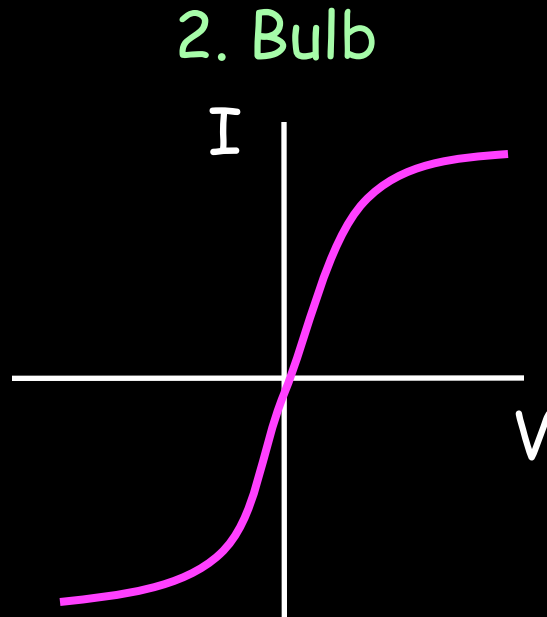

3. Diode

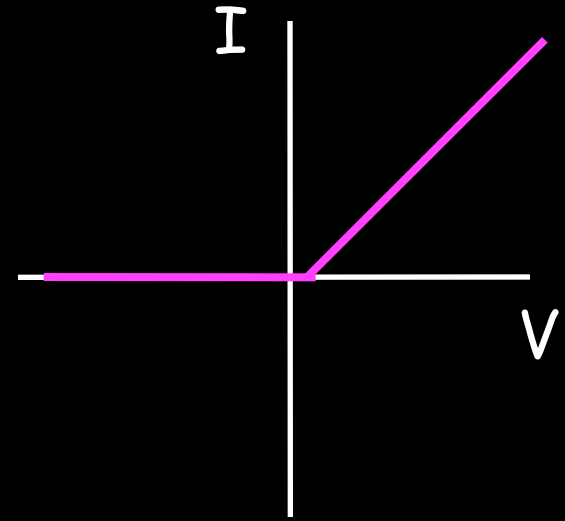

Explain the shape of each graph

Three simple components:

Three simple components:

- 1) Diode - only lets current flow in one direction

Three simple components:

- 1) Diode - only lets current flow in one direction
- 2) Light dependant resistor - resistance DECREASES when light intensity INCREASES

Three simple components:

- 1) Diode - only lets current flow in one direction
- 2) Light dependant resistor - resistance DECREASES when light intensity INCREASES
- 3) Thermistor - resistance DECREASES when temperature INCREASES